

### Bed Gssembly1/3

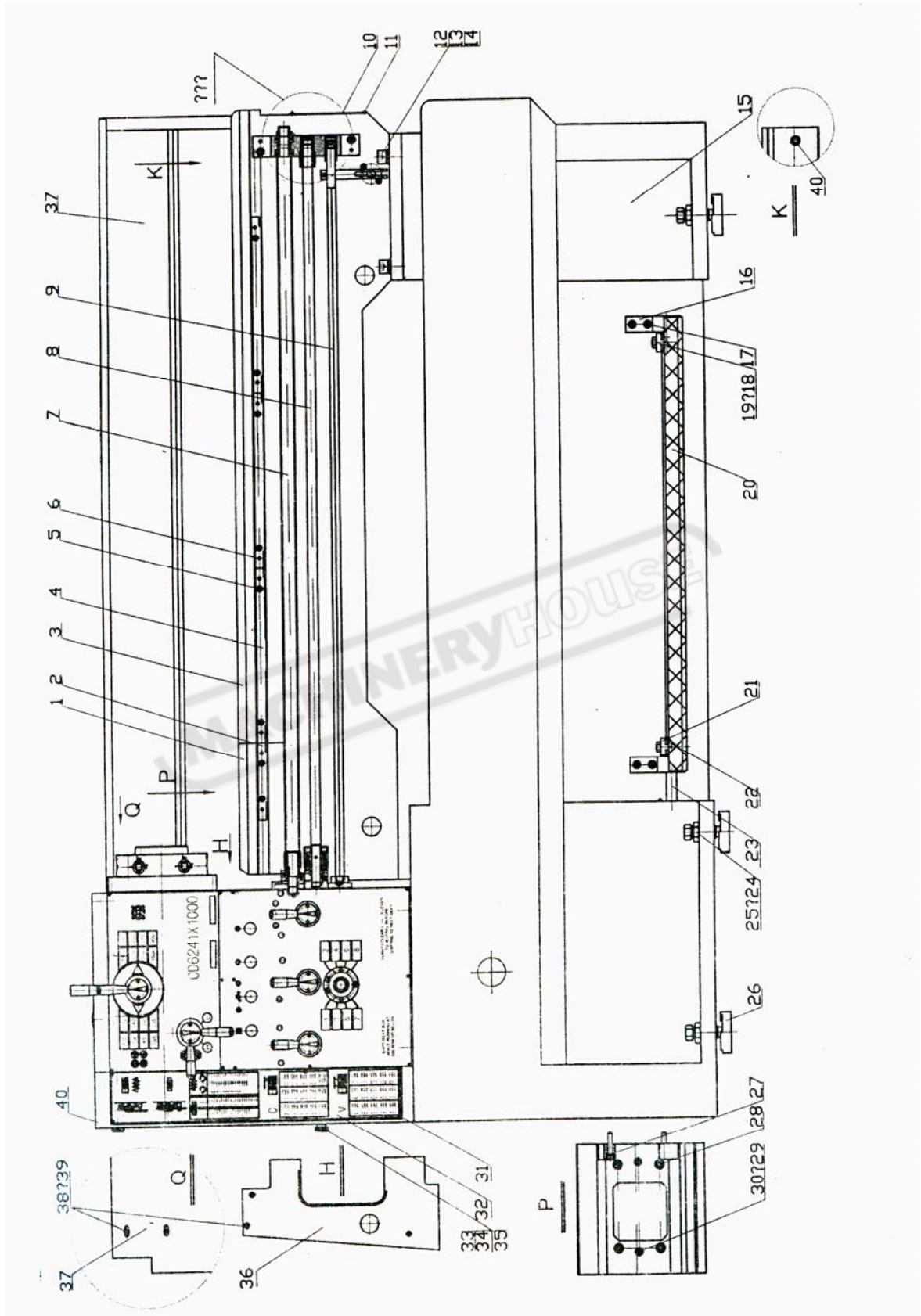

### Bed Gssembly2/3

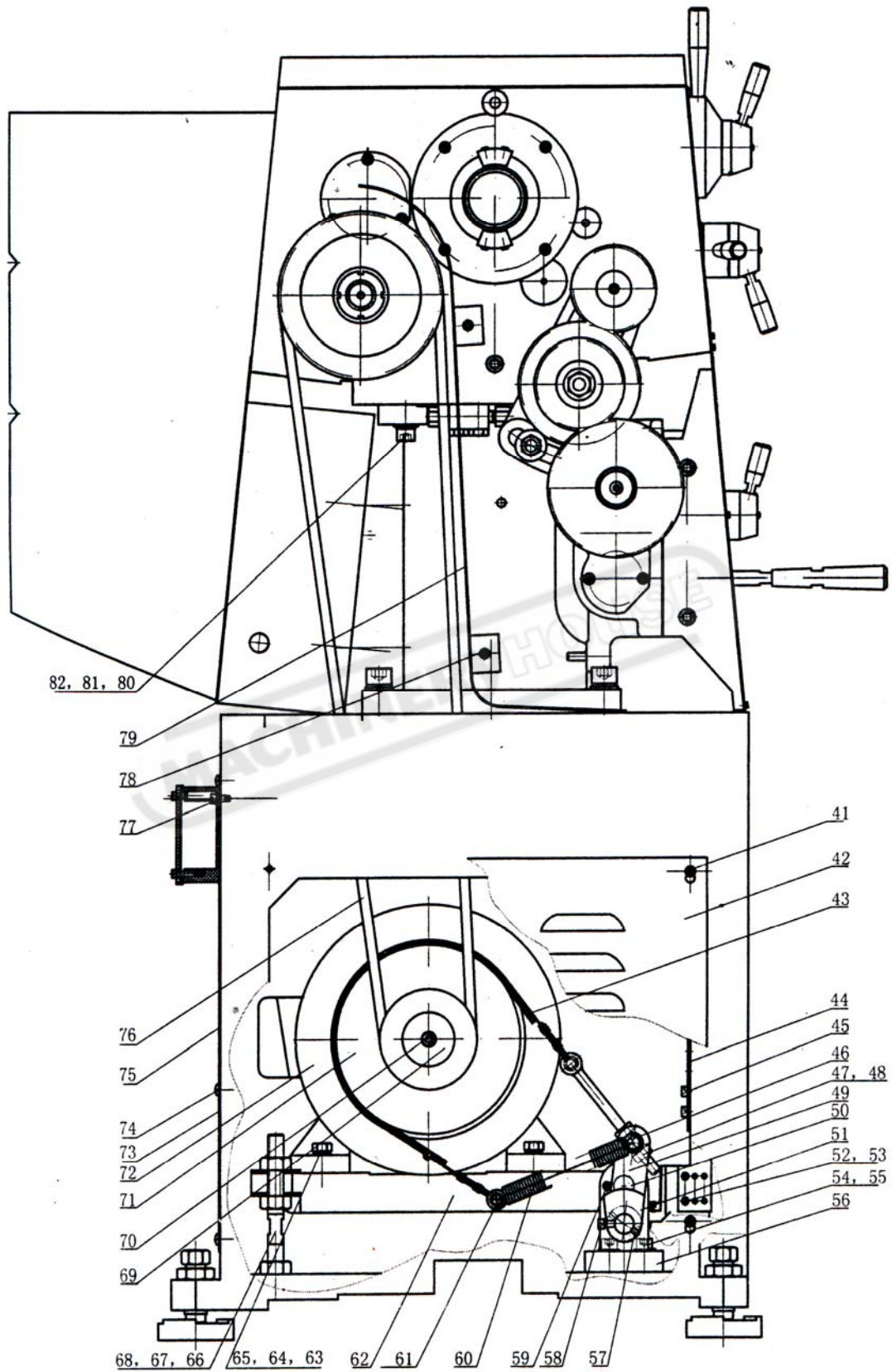

### Bed Gssembly3/3

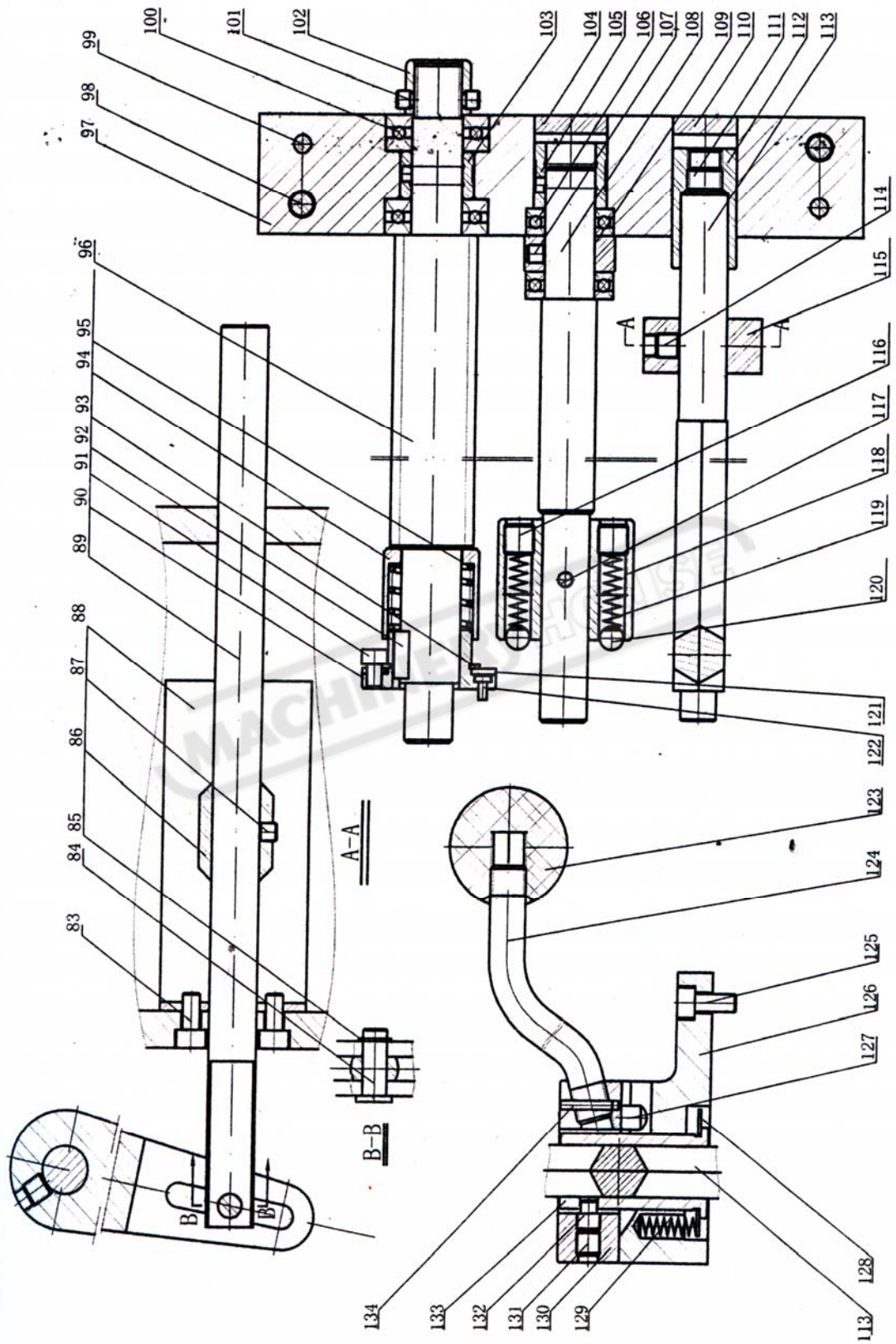

<b>Code</b>	<b>Name</b>	<b>Function</b>	<b>Electric Rating</b>
M1	AC 3PH Motor	Spindle	YD132M-8/4 3/4KW 400V 50HZ
M2	Pump	Coolant	AB25 90W 400V 50HZ
FU1	Fuse	Main Circuit Protection	RT18 32A
FU2	Fuse	Control Circuit Protection	RT18A 5A
FU3	Fuse	Working Lamp Protection	RT18 3A
S	Switch	Power On/Off	LW8GS-25/4-2
SA	Switch	High/Lower Speed	LW8PS-25/4D305
TC	Transformer	Control Voltage	JBK3-160 400V/24V
KM1	Ac Contactor	Forward Control	3TB4322 24V50HZ
FR1	Thermo relay	M1 Overload Protection	3UA5240 10-16A
FR2	Thermo relay	M2 Overload Protection	3UA5040 0.25-0.4A
EL	Working Lamp	Working Lamp	JC34A 24V50W
HL1	Indicator Lamp	Power Indicator	LA58-XD 24V
SBO	Button	Emergency Stop	LA58-01ZS/1
SB1	Button	Jog Control	LA58-10
SB2	Button	Pump Switch	LA58-10X
SQ1	Limit Switch	brake Control	LXW5-11G1
SQ2	Limit Switch	Chuck Cover Protection	LXW5-22
SQ3	Limit Switch	Safe Limit Switch	LWW5-11M
SQ4	Limit Switch	Forward Limit Switch	LXW5-11Q1
SQ5	Limit Switch	Reverse Limit Switch	LXW5-11Q1



## Bed Gssembly(1)

No.	code	name	Specification	Qty	Notes
1	.01-002	Bridge		1	
2	.01-037	Rack		1	
3	.01-001	Bed		1	
4	.01-035	Rack		3	
5	GB/T70.1-2000	Screw	M6 × 30	8	
6	GB/118-2000	Pin	6 × 30	8	
7	.01-004	Lead Screw		1	
8	.01-012	Light Bar		1	
9	.01-017	Bar		1	
10	.01-036	Cover		1	
11	GB/T818-2000	Screw	M6 × 10	4	
12	GB/TB70.1-2000	Screw	M16 × 60	8	
13	GB/T93-1997	Washer	16	8	
14	GB/T97.1-2002	Washer	16	8	
15	.01-101	Base		1	
16	.01-114	Seat		1	
17	GB/T70.1-2000	Screw	M8 × 22	4	
18	GB/T77-2000	Screw	M10 × 30	2	
19	GB/T41-2000	Nut	M10	2	
20	.01-117	Plate		1	
21	.01-115	Plate		2	
22	GB/T70.1-2000	Screw	M6 × 15	8	
23	.01-113	Shaft		1	
24	C6241	Screw		6	Borrow
25	GB/T6176-2000	Nut	M24 × 2	6	
26	C6241-1015	Iron		6	Borrow
27	GB/T70.1-2000	Screw	M8 × 40	2	
28	GB/T70.1-2000	Screw	M10 × 45	4	
29	GB/T881-2000	Pin	8 × 85	2	
30	GB/T6172.1-2000	Nut	M8	2	
31	GB/T70.1-2000	Screw	M3 × 6	8	
32	.02-106	Sign		1	
33	.02-106	Nut	M10	1	
34	GB/T900-88	Bolt	M10 × 160	1	
35	GB/T6176-2000	Nut	M10	1	

## Bed Gssembly (2)

N o	code	name	Specification	Qty	Notes
36	.03-094	Cover		1	
37	.01-038	Block Chip Board		1	
38	GB/T70.1-2000	Screw	M6 × 10	6	
39	GB/T97.1-2000	Washer	6	6	
40	.02-104	Cover		1	
41	GB/T818-2000	Screw	M6 × 10	4	
42	01-324	Cover		1	
43	.01-116	Belt Brake		1	
44	.01-120	Seat		1	
45	GB/T70.1-2000	Screw	M6 × 15	2	
46	.01-109	Shaft		1	
47	GB/T41-2000	Nut	M10	2	
48	GB/T97.1-2002	Washer	10	2	
49	.01-105	Arm Bark		1	
50	.01-111	Shaft		1	
51	.01-107	Cam		1	
52	GB/T818-2000	Screw	M4 × 30	2	
53	GB/T41-2000	Nut	M4	2	
54	GB/T70.1-2000	Screw	M6 × 40	3	
55	GB/T97.1-2000	Washer	16	3	
56	.01-104	Bracket Motor Seat		1	
57	GB/T879.2-2000	Pin	5 × 40	1	
58	GB/T70.1-2000	Screw	M6 × 15	1	
59	GB/T70.1-2000	Screw	M5 × 20	2	
60	.01-112	Spring	φ 3 × 9 × 100	1	
61	.01-110	Shaft		1	
62	.01-103	Motor Seat		1	
63	GB/T5780-2000	Bolt	M10 × 40	4	
64	GB/T93-1997	Washer	10	4	
65	GB/T97.1-2002	Washer	10	4	
66	.01-108	Bolt	M16 × 165	2	
67	GB/T96.1.2-2002	Washer	16	4	
68	GB/T41-2000	Nut	M16	6	
69	.01-106	Cover		1	
70	GB/T70.1-2000	Screw	M8 × 20	1	

## Bed Gssembly(3)

No.	code	name	Specification	Qty	Notes
71	.01-102	Belt Pulley		1	
72	.01-102	Motor	YD132S-8/4	1	
73	.01-122	Cover		1	
74	GB/T818-2000	Screw	M6 × 10	8	
75	.01-121	Cover		1	
76		Belt		3	
77	GB/T70.1-2000	Screw	M6 × 20	1	
78	GB/T70.1-2000	Screw	M6 × 10	2	
79	.02-103	Cover		1	
80	GB/T70.1-2000	Screw	M12 × 45	2	
81	GB/T97.1-2002	Washer	12	2	
82	GB/T93-1997	Washer	12	2	
83	GB/T70.1-2000	Screw	M6 × 12	2	
84	.01-022	Shaft		1	
85	GB894.2-86	Circlip	8	1	
86	.01-023	Sleeve		1	
87	GB/T77-21000	Screw	M6 × 6	1	
88	.01-024	Seat		1	
89	.01-021	Shaft		1	
90	.01-005	Sleeve		1	
91	GB/T70.1-2000	Screw	M5 × 8	1	
92	GB/T1567-79	Key	5 × 5 × 16	1	
93	GB894.2-86	Circlip	28	1	
94	.01-009	Cover		1	
95	.01-008	Spring	1.8 × 50 × 26. 2 × 18	1	
96	.01-004	Lead Screw		1	
97	.01-003	Bracket		1	
98	GB/T70.1-2000	Screw	M8 × 35	2	
99	GB/T301-95	Pin	6 × 50	2	
100	GB/T301-95	Shaft	51203	2	17 × 35 × 12
101	GB/T80-2000	Screw	M6 × 8	2	
102	.01-011	Nut		1	
103	.01-010	Copper Bush		1	
104	01-016.	Cover		1	
105	.01-015	Copper Bush		1	

## Bed Gassembly(4)

No.	Code		name	Specification	Qty	Notes
106	GB/T301-95		Shaft	51103	2	17 × 30 × 9
107	GB/T77-200	0	Screw	M6 × 6	1	
108	.01-01	2	Light Bar		1	
109	.01-01	4	Circlip		1	
110	.01-01	9	Cover		1	
111	GB/T77-200	0	Screw	M12 × 8	1	
112	.01-02	0	Sleeve		1	
113	.01-10	7	Bar		1	
114	GB/T77-200	0	Screw	M8 × 8	1	
115	.01-02	0	Lever		1	
116	GB/T77-200	0	Screw	M10 × 10	1	
117	GB/T879.2-2	000	Pin	5 × 45	1	
118	.01-01	3	Clutch		1	
119	GB2089-	94	Spring	1.2 × 6 × 46	4	
120	GB308-8	9	Steal Ball	8	4	
121	.01-00	6	Washer		1	
122	.01-00	7	Pin		1	
123	JB1340		Ball(red)	M12 × φ 40	1	
124	.01-02	6	Handle(Bar)	1		
125	GB/T70.1-20	00	Screw	M6 × 14	2	
126	.01-00	5	Seat		1	
127	C624	1-1027	Pin		1	
128	C624	1-1028	Spring Washer		1	Borrow
129	GB2089-	94	Spring	1 × 6 × 22	3	
130	C624	1-1026	Handle Block		1	Borrow
131	GB/T77-200	0	Screw	M8 × 8	2	
132	GB/T79-200	0	Screw	M8 × 10	2	
133	C624	1-1024	Sleeve		1	Borrow
134	GB/T879.2-2	000	Pin	3 × 18	1	



# Distance Institution Set

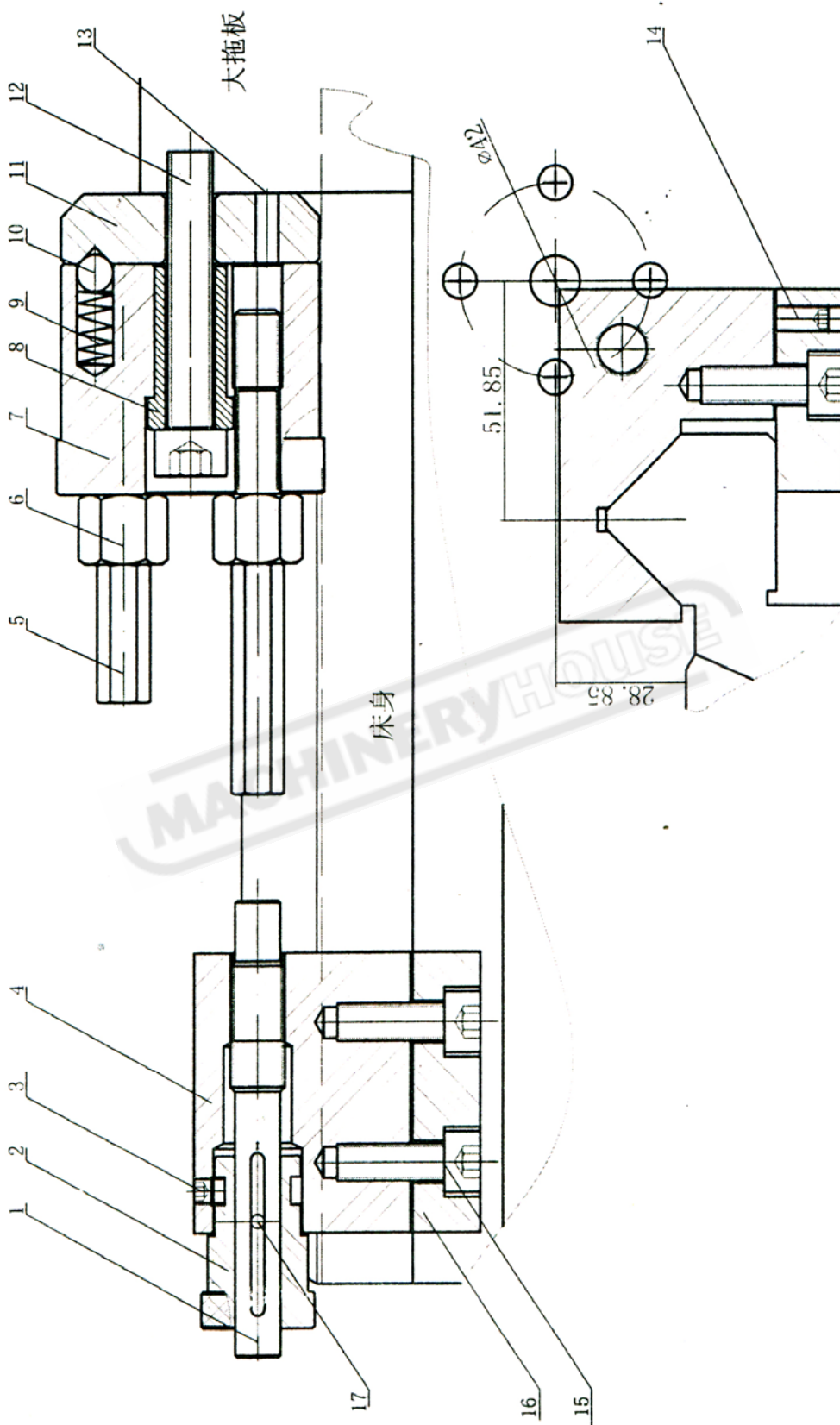

## Distance Institution Set

<b>N0.</b>	<b>code</b>	<b>Name</b>	<b>specification</b>	<b>Qty</b>	<b>Notes</b>
1	0.1-033	Shaft		1	
2	.01-034	Scale Ring		1	
3	GB/T79-2000	Screw	M6 × 6	1	
4	.01-031	Seat		1	
5	.01-030	Location Bar		4	
6	GB/T56-2000	Nut	M10	4	
7	.01-023	Sleeve		1	
8	.01-029	Circlip		1	
9	GB2089-94	Spring	1 × 6 × 20 × P3	1	
10	GB308-89	Ball	8	1	
11	.01-027	Location Block		1	
12	GB/T70.1-2000	Screw	M10 × 10	1	
13	GB/T879.2-2000	Pin	5 × 20	1	
414	GB/T79-2000	Screw	M6 × 12	2	
15	GB/T70.1-2000	Screw	M8 × 20	2	
16	.01-032	Plate		1	
17	GB/T8792.-200	Pin	5 × 6	1	

# Headstock Assembly (1/3)

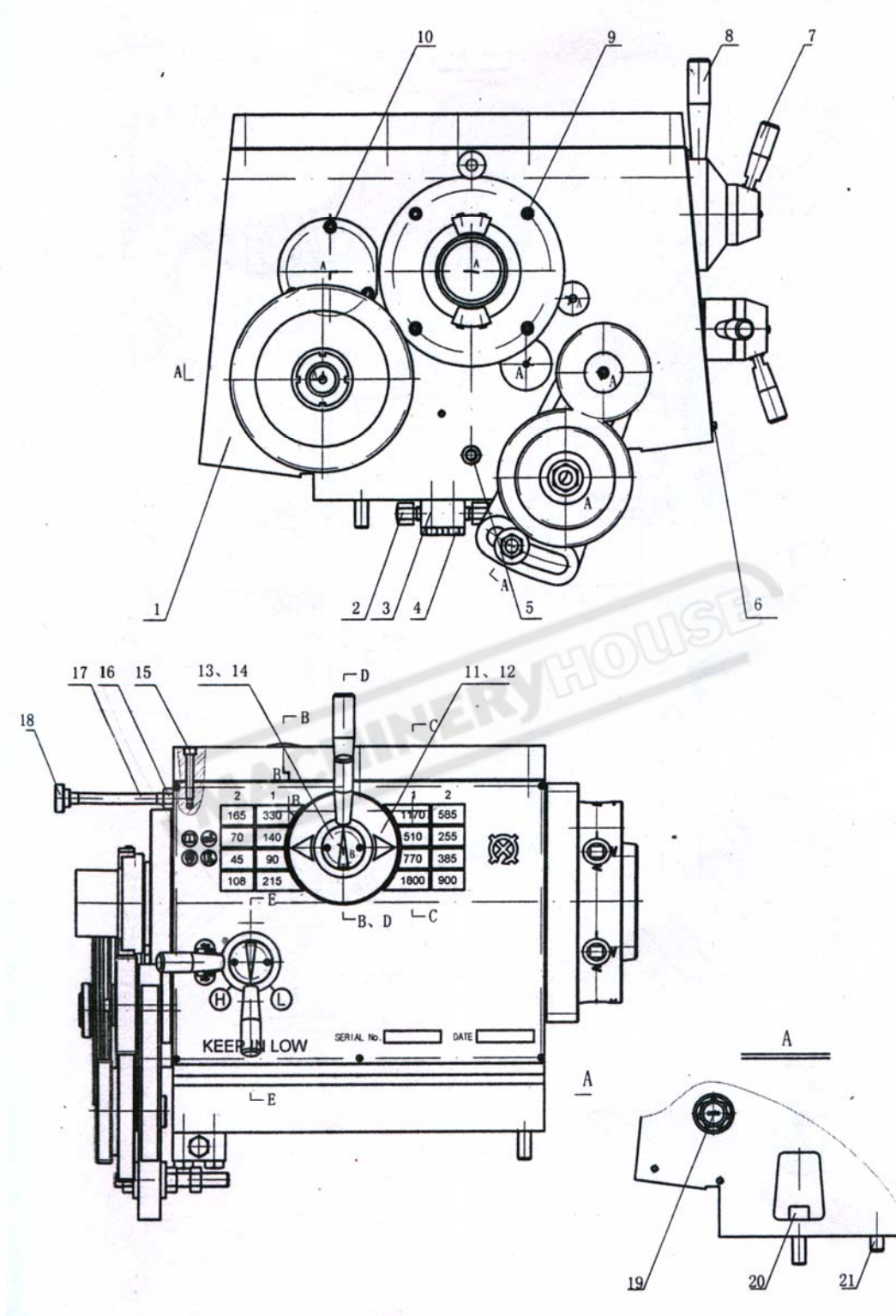

# Headstock Assembly (2/3)

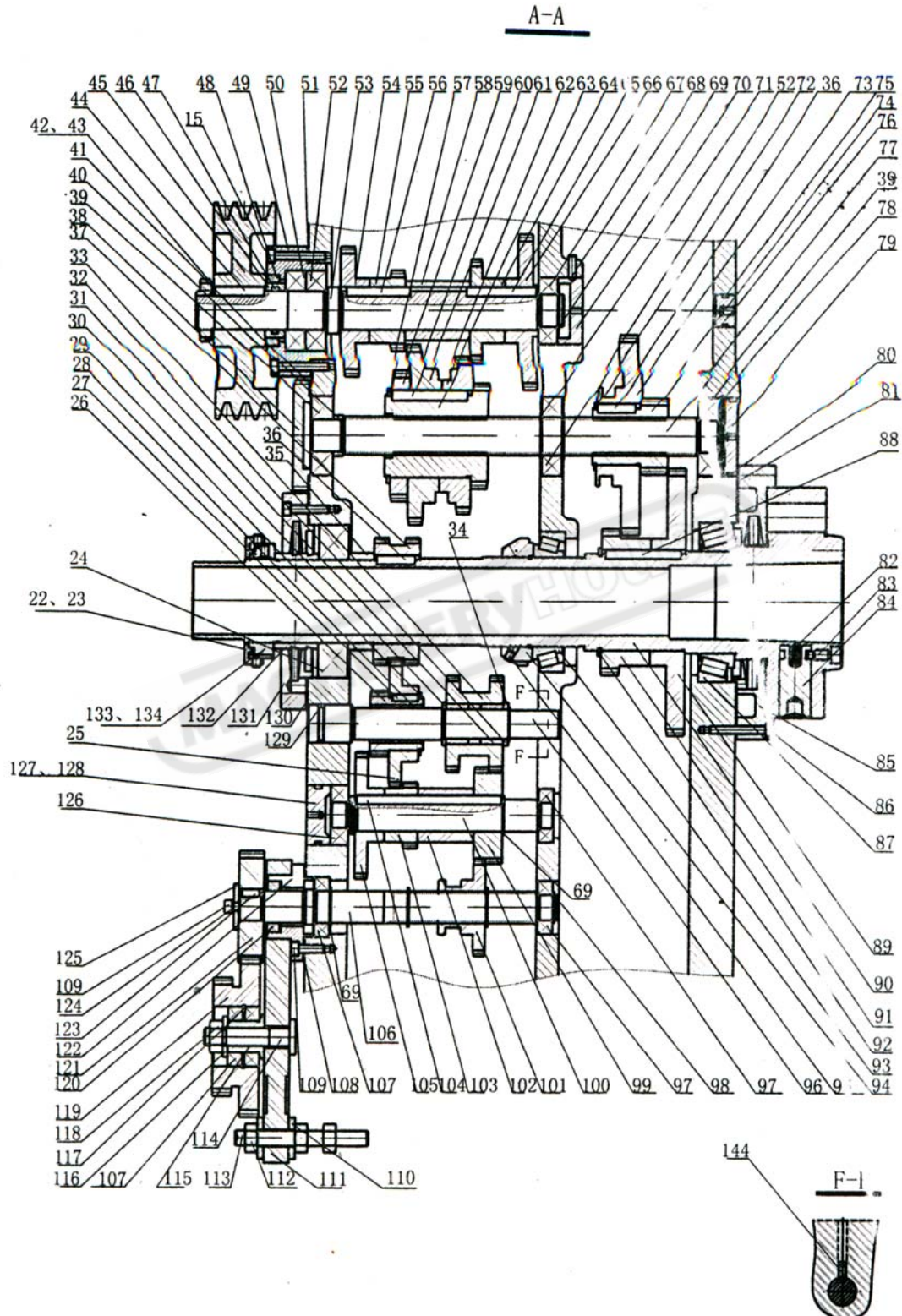



# Headstock Assembly (3/3)

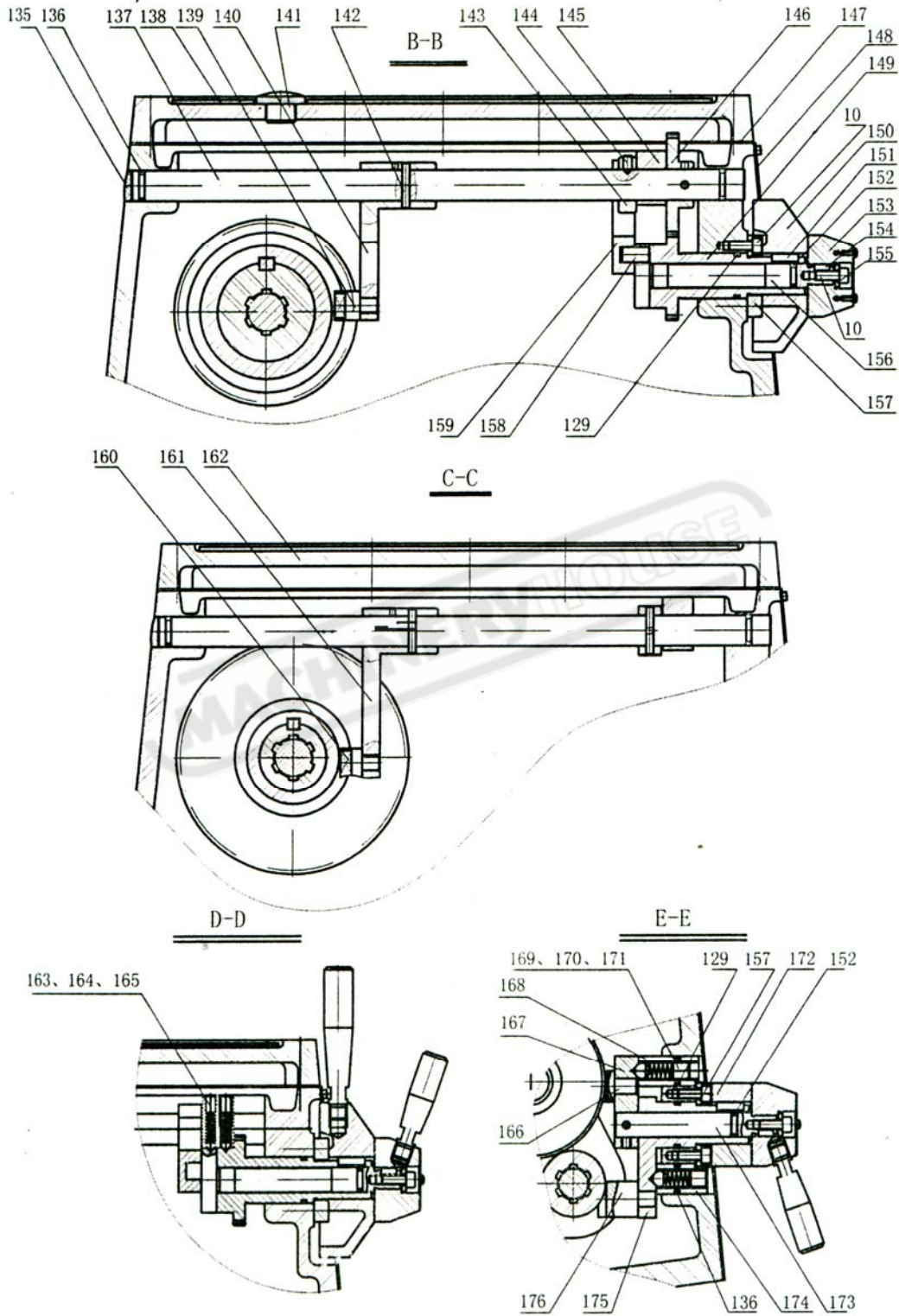

## Headstock Assembly(1)

No.	code	name	Specification	Qty	Notes
1	.02-001	Headstock		1	
2	.02-002	Screw		2	
3	.02-003	Support Block		1	
4	GB/T5781-2000	Bolt	M10 × 35	2	
5	GC290-60	Oil plug	ZG3/8"	1	
6	GB/70.1-2000	Screw	M3 × 6	5	
7	.02-004	Handle		3	
8	.02-005	Handle		1	
9	GB/T70.1-2000	Screw	M × 625	4	
10	GB/T70.1-2000	Screw	M6 × 16	9	
11	GB827-86	Rivet	2 × 5	9	
12	.02-007	Plate		1	
13	Gb818-85	Screw	M3 × 8	4	
14	.02-007	Plate		2	
15	GB/T70.1-2000	Screw	M6 × 40	13	
16	GB/T6175-2000	Nut	GB/T6172.1 M10	1	
17	GB/T900-88	Stud	M10 × 100	1	
18	.02-008	Nut		1	
19	JB/T7941.1	Sign	A20	1	GB1160.1-89
20	GB/T70.1-2000	Screw	M12 × 40	2	
21	GB/T119.1-2000	Pin	12h6 × 30	1	
22	.02-009	Limited Bracket		2	
23	GB/T79-2000	Screw	M6 × 10	4	
24	GB/TT276-94	Shaft	6213/P6	1	65 × 120 × 23
25	.02-010	IV Gear		1	M2 z48
26	.02-011	IV Gear		1	M2 z24
27	GB/T1096-79	Key	5 × 5 × 20	1	
28	.02-012	IV Copper Bush	25 × 30 × 18.5	2	
29	GB/T894.2-86	Circlip		1	
30	.02-013	IV SPacer		1	
31	.02-014	IV Copper Bush	23 × 32 × 18	2	
32	.02-015	IV Spacer		1	
33	.02-016	IV Gear		1	M2 z36
34	GB/T894.2-86	Circlip	22	1	
35	.02-017	Sleeve		1	
36	GB/T1096-79	Key	8 × 7 × 30	1	
37					
38	.02-019	II Flange		1	
39	GB/T276-94	Shaft	6305Z	2	25 × 62 × 17
40	.02-020	II Spacer		1	
41	.02-021	II Packing	NY400 δ =1	1	
42	GB/T812-88	Nut	M30 × 1.5	1	
43	GB/T858-88	Washer	30	1	
44	GB/T1096-79	Key	8 × 7 × 35	1	
45	.02-022	Belt Pulley		1	

## Headstock Assembly (2)

NO.	code	name	specification	Qty	Notes
46	.02-023	Spacer		1	
47	GB3452.1-82	O-Ring	30 × 3.55	1	
48	GB13871-92	Oil Seal	FB42 × 55 × 9	1	42 × 55 × 9
49	.02-024	I Flange		1	
50	GB/T276-94	Shaft	6206Z	1	30 × 62 × 16
51	.02-025	I Packing	NY400 δ=1	1	
52	GB/T276-94	Shaft	6206	2	30 × 62 × 16
53	.02-026	I Shaft		1	
54	.02-027	I Gear		1	m 2.5 z38
55	.02-028	I Gear	1	1	m 2.5 z23
56	GB/T1096-79	Key	8 × 7 × 50	1	
57	GB/T894.2-65	Circlip		1	
58	.02-029	I Spacer		1	
59	.02-030	II Gear		1	m 2.5 z39
60	GB/T1096-79	Key	10 × 8 × 6	1	
61	.02-031	II Gear		1	m 2.5 z54
62	.02-023	II Gear		1	m 2.5 z47
63	.02-033	II Gear		1	m 2.5 z31
64	.02-034	I Gear		1	m 2.5 z30
65	GB/T1096-79	Key	8 × 7 × 56	1	
66	.02-035	I Gear		1	m 2.5 z46
67	GB/T276-94	Shaft	6205	1	25 × 52 × 15
68	GB/T78-2000	Screw	M6 × 20	1	
69	GB/T894.2-86	Circlip	25	5	
70	.02-036	I Plug 1		1	
71	GB/T894.2-86	Circlip	30	2	
72	GB/T894.2-86	Circlip	45	1	
73	.02-037	II Gear		1	m 2.5 z60
74	.02-038	II Gear		1	m 2.5 z21
75	GB3452.1-82	O-Ring	19 × 2.65	1	
76	.02-039	I Plug 2		1	
77	.02-040	II Shaft		1	
78	GB/T893.2-86	Circlip	62	1	
79	.02-041	II Plug		1	
80	GB3452.1-82	O-Ring	56 × 3.55	1	
81	.02-042	Packing	NY400 δ=1	1	
82	GB/T2089-94	Spring	0.8 × 7 × 30	6	
83	.02-043	Screw	45(M8 × 20 内六角)	6	标准件改制
84	C6241-2034	Shaft		6	借用
85	.02-045	Flange		1	
86	GB/T70.1-2000	Screw	M6 × 45	6	
87	GB/T297-94	Shaft	32016P5	1	80 × 125 × 29
88	GB/T1096-79	Key	8 × 7 × 60	1	
89	.02-046	Gear	8 × 7 × 60	1	
90	.02-047	Shaft		1	m 2.5 z82



## Headstock Assembly(3)

N0.	code	name	Specification	Qty	Notes
91	.02-048	Gear		1	m 2.5 z43
92	GB/T894.2-86	Circlip	75	1	
9++3	GB/T297-94	Shaft	32014P5	1	70 × 110 × 25
94	.02-049	Nut	M70 × 1.5	1	
95	GB/T77-2000	Screw	M6 × 8	3	
96	.02-050	IV Shaft		1	
97	GB/T297-94	Shaft	6004	2	20 × 42 × 12
98	GB/T894.2-86	Circlip	20	1	
99	.02-051	V Gear		1	m 2 z36
100	.02-052	V Shaft		1	
101	.02-053	VI Gear		1	m 2 z36
102	.02-054	V Spacer		1	
103	.02-055	V Gear		1	m 2 z24
104	GB/T1096-79	Key	8 × 7 × 115	1	
105	.02-056	V Gear		1	m 2 z48
106	.02-057	VI Shaft		1	
107	GB/T276-94	Shaft	6005Z	3	25 × 47 × 12
108	.025-058	VI Packing	NY400 δ =1	1	
109	GB/T70.1-2000	Screw	M6 × 20	4	
110	.02-059	External Circlip		1	
111	.02-060	Gear Rack		1	
112	GB/T41-2000	Nut	M12	1	
113	.02-061	Screw		1	
114	.02-062	Shaft		1	
115	.02-063	Sleeve		1	
116	.02-064	Spacer		1	
117	GB/T893.2-86	Circlip	47		
118	GB/T41-2000	Nut	M14	1	
119	.02-065	Change Gear		1	m2.5z35m2.5z21
120	GB13871-92	Oil Plug	FB25 × 40 × 10	1	
121	.02-066A	33 Tooth Gear		1	m 2.5 Z33
	.02-066B	21 Tooth Gear		1	m 2.5 Z21
122	.02-067	IV Flange		1	
123	GB/T1096-79	Key	6 × 6 × 14	1	
124	GB/T93-97	Circlip	6	1	
125	.02-068	Spacer		1	
126	GB/T276-94	Shaft	6204	1	
127	.02-069	V Plug		1	
128	GB3452.1-82	O-Ring	41.2 × 3.55	1	
129	GB3452.1-82	O-Ring	25 × 2.65	3	
130	.02-070	Packing	NY400 δ =1	1	
131	.02-071	Flange		1	
132	.02-072	Nut		1	
133	.02-073	Nut		1	
134	GB/T77-2000	Screw	M6 × 10	1	

## Headstock Assembly(4)

No.	code	name	Specification	Qty	Notes
135	.02-074	Plug		2	
136	GB3452.1-82	O-Ring	15 × 2.65	6	
137	.02-075	Fork		2	
138	.02-076	Rubber Pad		1	
139	.02-077	Fork		1	
140	.02-078	Lever		1	
141	.02-079	Screw		1	
142	GB/T879.2-2000	Pin	5 × 30	5	
143	.02-080	Sleeve		1	
144	GB/T78-2000	Screw	M6 × 12	2	
145	.02-081	Bracket		1	
146	.02-082	Gear		1	m 1.5 z37.
147	.02-083	Packing	NY400 δ =1	1	
148	.02-084	Nameplate		1	
149	.02-085	Gear		1	m 1.5 z37
150	.02-086	Lever Bracket		1	
151	GB/T1096-79	Key	5 × 5 × 18	2	
152	GB/T3452.1-82	O-Ring	11.2 × 2.65	2	
153	0.2-087	Bracket		2	
154	GB/T1096-79	Key	4 × 4 × 10	2	
155	.02-088	Spacer		2	
156	.02-089	Shaft		1	
157	.02-090	Flange		2	
158	GB/T119.1-2000	Pin	10h6 × 19	1	
159	.02-091	Rocker		1	
160	.02-092	Fork		1	
161	.02-093	Lever		1	
162	.02-094	Headstock Lever		1	
163	GB/T77-2000	Screw	M8 × 12	2	
164	GB/T2089-94	Spring	1 × 5 × 22	2	
165	GB308-89	Ball	6.5	1	
166	.02-095	Fork		1	
167	.02-096	Lever		1	
168	.02-097	Bracket		1	
169	GB/T77-2000	Screw	M12 × 10	2	
170	GB/T2089-94	Spring	0.9 × 9 × 35	2	
171	GB308-89	Steal Ball	10	2	
172	.02-098	Shaft		1	
173	.02-099	Shaft		1	
174	.02-100	Bracket		1	
175	.02-101	Lever		1	
176	.02-102	Fork		1	

# Gear Box Control (1/4)

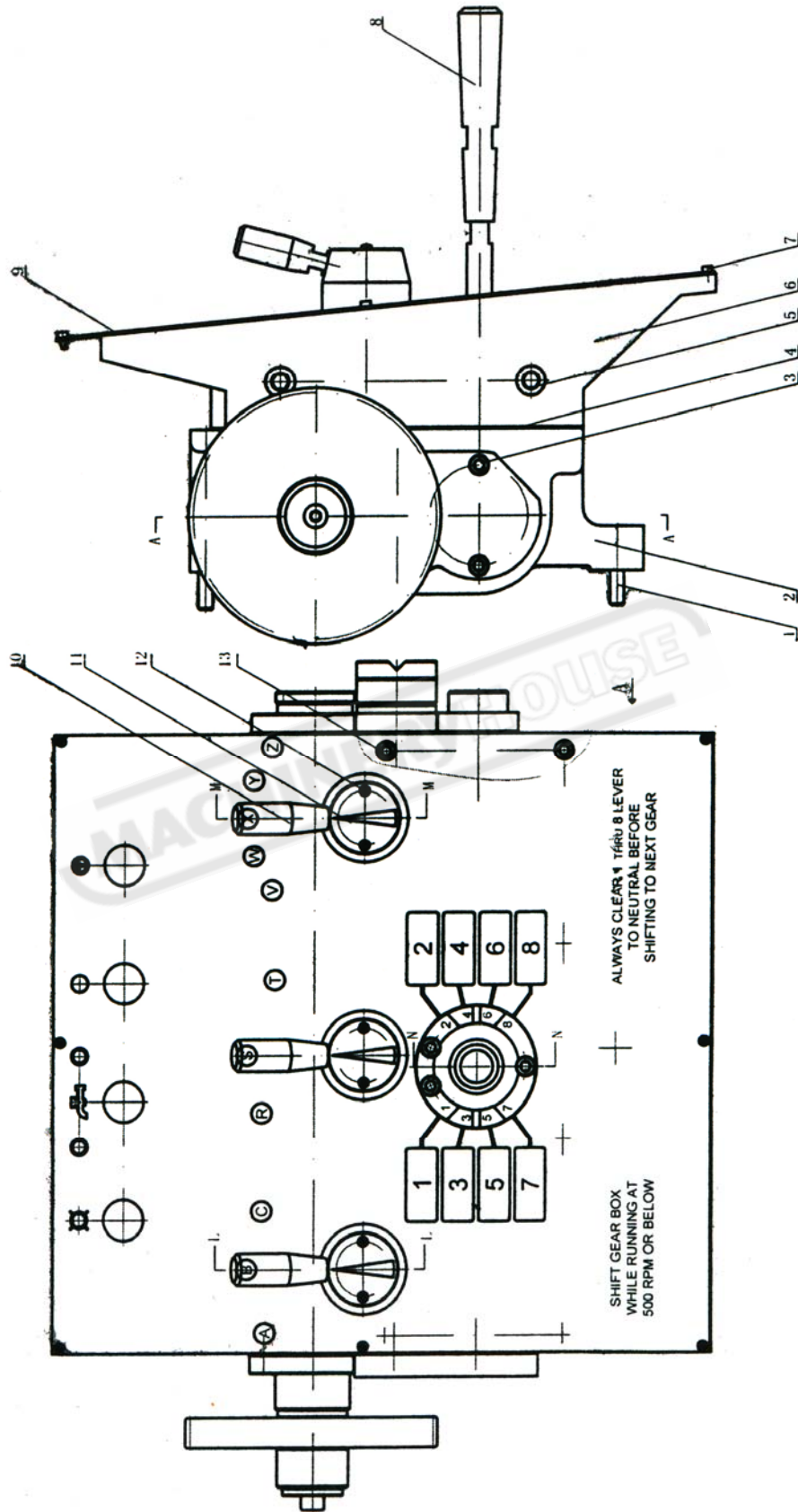

# Gear Box Control (2/4)

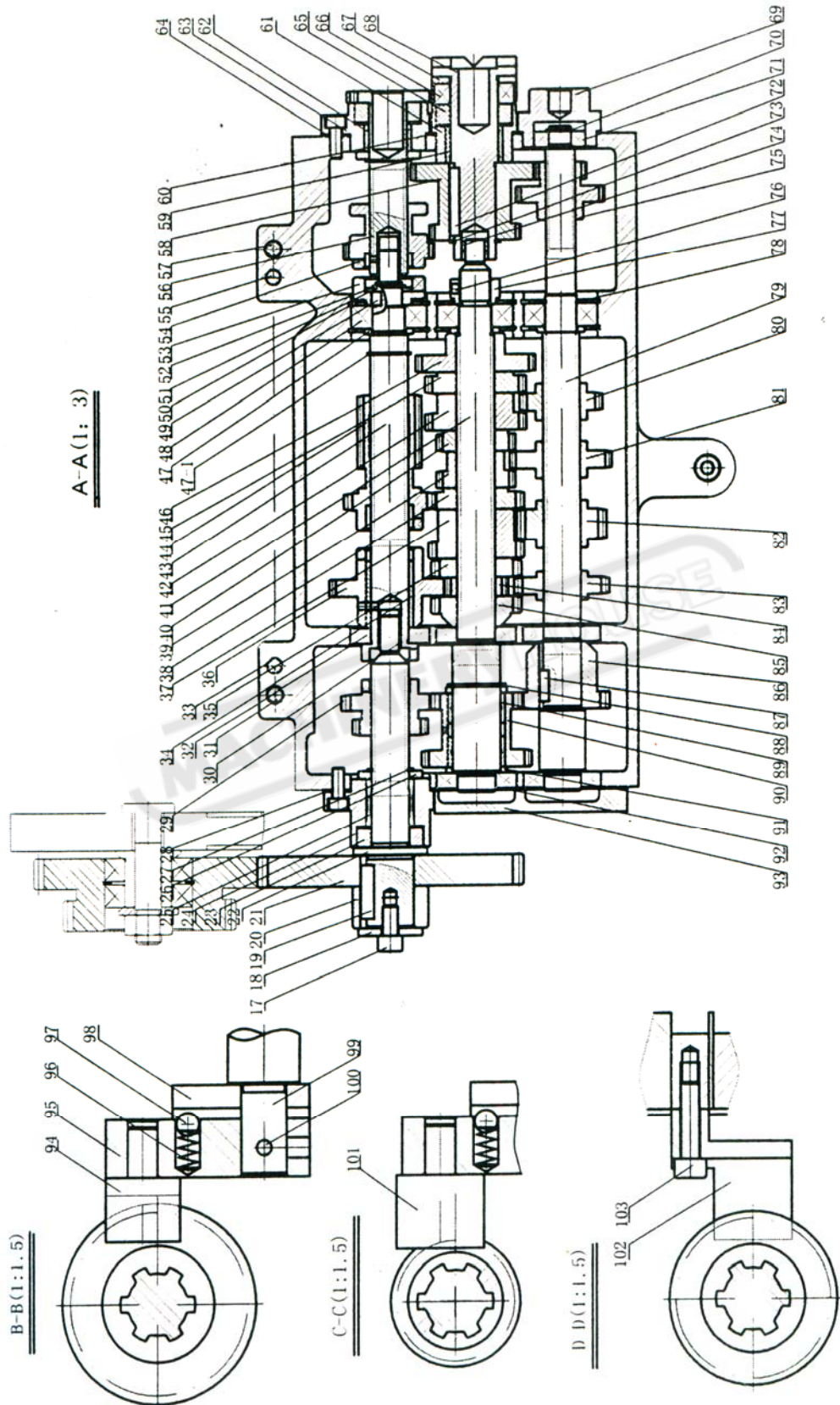

# Gear Box Control (3/4)

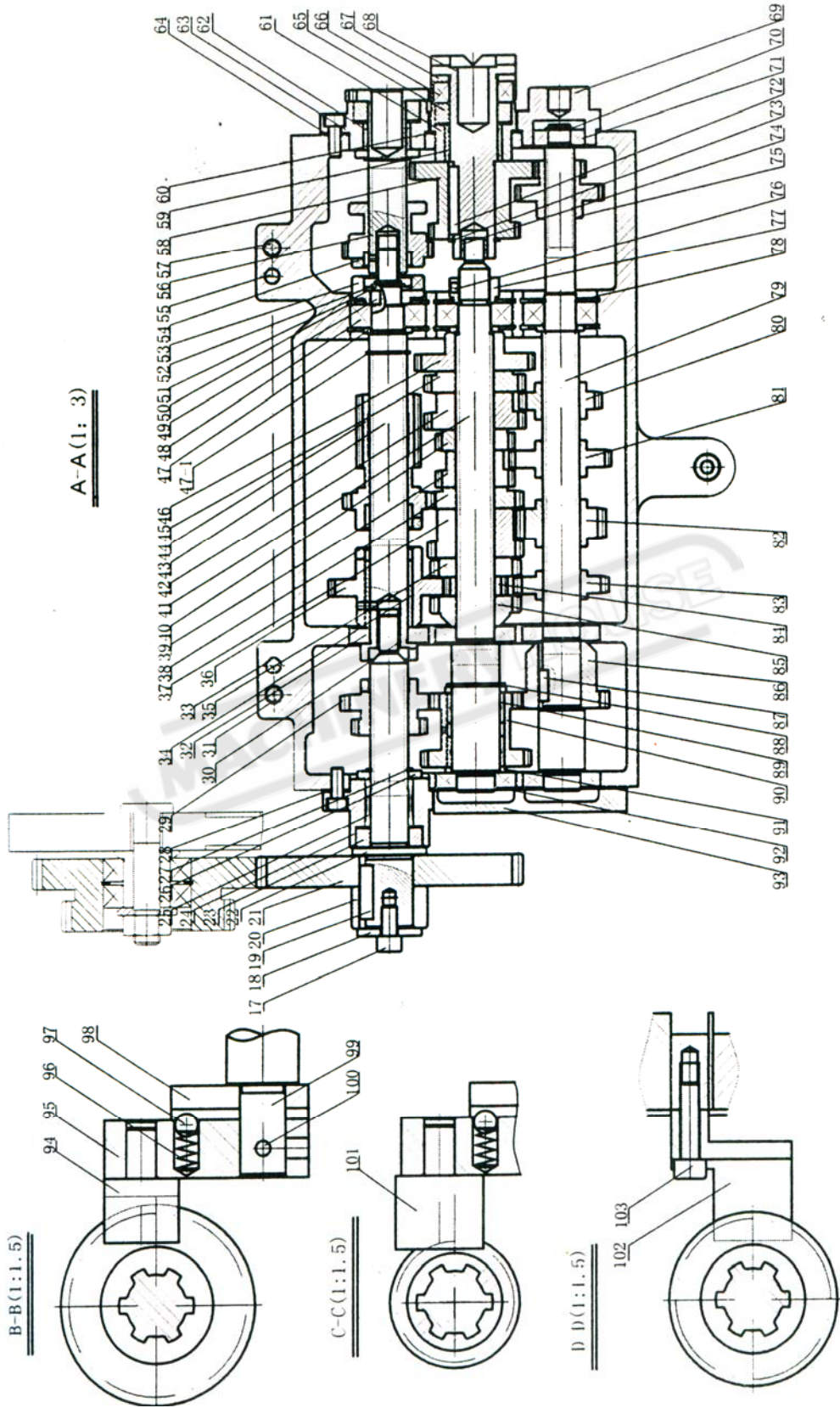



# Gear Box Control (4/4)

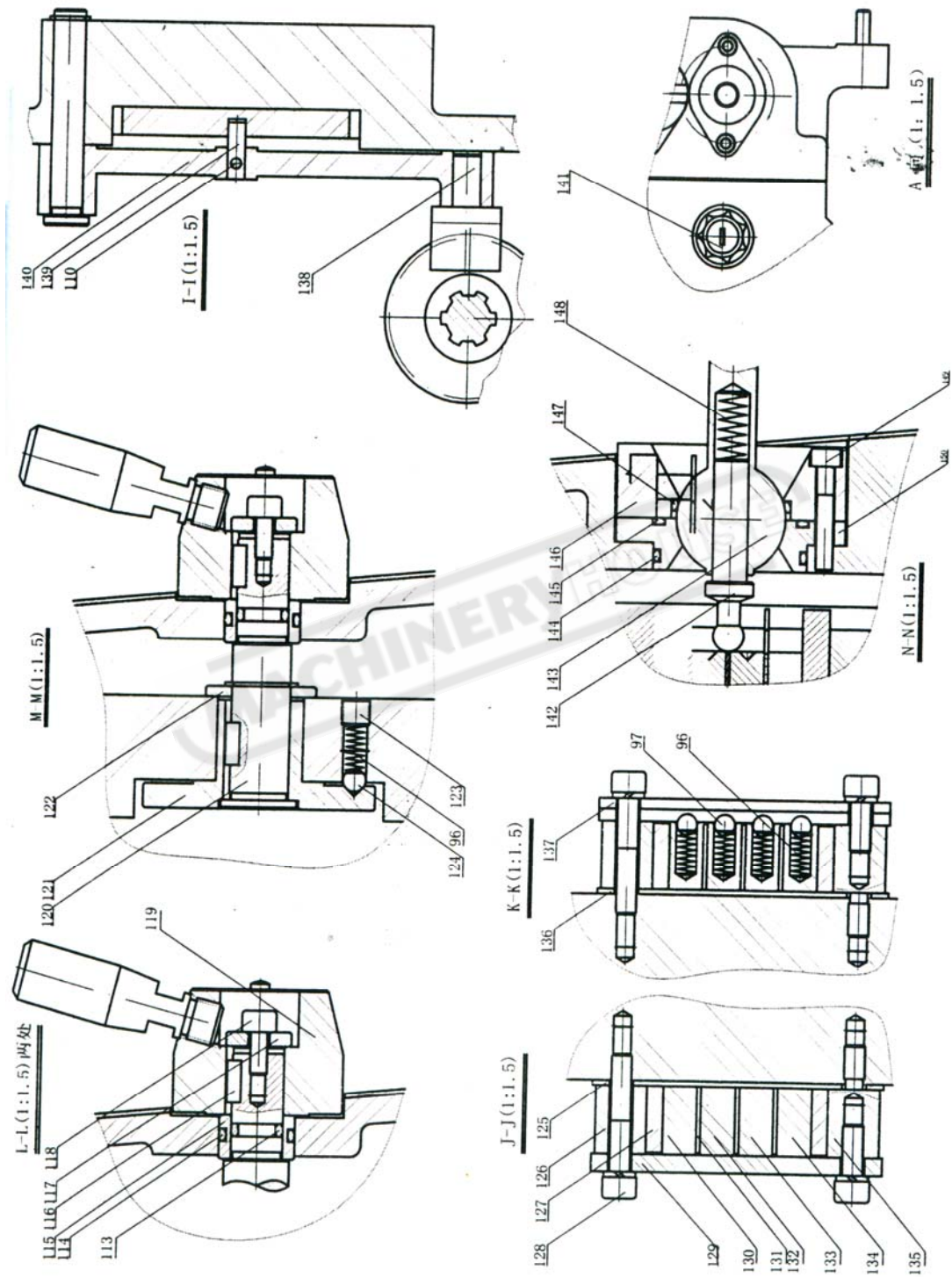

## Gear Box Control(1)

NO.	code	Name	specification	Qty	Notes
1	GB/T70.1-2000	Screw	M8 × 35	1	
2	.03-001	Gear Box Casting		1	
3	GB/T70.1-2000	Screw	M6 × 16	18	
4	.03-002	Packing	NY400 δ =1	1	
5	GB3289.2-82	Oil Inlet Pip	ZG3/8"	2	
6	.03-003	Cover		1	
7	GB/T70.1-2000	Screw	M3 × 6	8	
8	.03-004	Handle		1	
9	.03-005	Sign		1	
10	.02-004	Handle		3	
11	.02-007	Sign		3	
12	GB/T818-2000	Screw	M3 × 8	6	
13	GB/T70.1-2000	Screw	M6 × 65	6	
14	GB/T879.2-2000	Pin	5 × 18	12	
15	GB/T70.1-2000	Screw	M6 × 20	1	
16	GB/T93-1997	Washer	6	6	
17	GB/T70.1-2000	Screw	M8 × 16	1	
18	.03-006	Washer		1	
19	GB/T1096-79	Key	8 × 7 × 28	1	
20	.03-007	Sleeve		1	
21	.03-008A	Change Gear		1	m 2 5 Z54
	.03-008B	Change Gear		1	m 2 5 Z60
22	.03-009	I - I Shaft		1	
23	GB13871-92	Oil Seal	FB20 × 35 × 15	2	
24	.03-010	I - I Shaft Flange		1	
25	GB290-64	Shaft	943/20	1	
26	.03-011	I - I Spacer		2	
27	GB/T894.-2-86	Circlip	20	4	
28	.03-012	I - I Packing	NY400 δ =1	1	
29	.03-013	I - I Gear		1	m1.75z2、 m2.25z19
30	GB/T12613	Sleeve	12 × 10 × 20	2	
31	GB/T70.1-2000	Screw	M8 × 65	1	
32	GB/T276-1994	Shaft	16004	5	20 × 42 × 8
33	GB/T118-2000	Pin	8 × 60	1	
34	.03-016	I - II Copper Bush	25 × 20 × 35	1	
35	.03-015	II - I Gear		1	m2 z20
36	.03-016	I - II Gear		1	m.5 z38
37	.03-017	II - I Gear		1	m 2 z24



## Gear Box Control (2)

N0.	Code	Name	specification	Qty	Notes
38	.03-018	II - I Gear		1	m 2 z23
39	.03-019	II - I Gear		1	m 1.5 z27
40	.03-020	II - I Gear		1	m 1.5 z24
41	.03-021	II - I Shaft		1	
42	.03-022	II - I Gear		1	m 1.75 z28
43	.03-023	I - II Shaft-		1	
44	.03-024	I - II Gear		1	m2 z23、 m1.5z19
45	.03-025	II - I Gear		1	m 1.75 z26
46	.03-026	II - I Gear		1	m1.5 z38
47	.03-027	Spacer		3	
47-1	GB/Tf894.2-86	Circlip	20	1	
48	GB/T276-1994	Shaft	6203	3	17 × 40 × 12
49	GB/T1096-79	Key	5 × 5 × 7	1	
50	GB/T893.2-86	Circlip	40	6	
51	.03-028	Washer		1	
52	GB/T894.2-86	Circlip	14	1	
53	.03-029	I - II Clutch		1	
54	.03-030	I - II Gear		1	m1.25 z35
55	GB/T118-2000	Pin	8 × 90	1	
56	.03-031	I - III Shaft		1	
57	GB/T70.1-2000	Screw	M8 × 90	1	
58	.03-023	II - II Gear		1	m1.25z36、 m1.25z50
59	.03-033	II - II Copper Bush	30 × 25 × 19	1	
60	.03-034	II - II Packing	NY400 δ =1	2	
61	.03-035	II - II Flange		1	
62	.03-036	I - II Copper Bush	25 × 20 × 14	1	
63	.03-037	I - II Flange		1	
64	.03-038	I - II Packing	NY400 δ =1	1	
65	GB13871-92	Oil Seal	FB25 × 40 × 10	1	
66	GB/T301-95.	Shaft	51005	1	25 × 42 × 11
67	.03-039	II - II Jacket		1	
68	.03-040	II - II Shaft		1	
69	.03-041	Flange		1	
70	GB/T894.2-86	Circlip	12	1	
71	GB/T276-94	Shaft	6001	1	12 × 28 × 8
72	GB/T1096-79	Key	5 × 5 × 35	1	
73	GB/T894.2-86	Circlip	22	1	
74	.03-024	II - II Copper Bush	14 × 10 × 10	1	

## Gear Box Control (3)

No.	Code	name	specification	Qty	Notes
75	.03-043	III Gear		1	m.25z 36、 m125z20
76	GB/T77-2000	Screw	M5 × 5	1	
77	.03-044	II- I Nut		1	
78	GB/T894.2-86	Circlip	17	2	
79	.03-045	III Shaft		1	
80	.03-046	III Gear		1	m 1.57z22
81	.03-047	III Gear		1	M 1.5 z33
82	.03-048	III Gear		1	m 2 z22
83	.03-049	III Gear		1	m 2 z22
84	.03-050	II- I Gear		1	m 1.5 19
85	.03-051	II- I Gear		1	m 2 z22
86	.03-052	III Gear		1	m 2.25 22
87	GB/T109679	Key	5 × 5 × 16	1	
88	GB/T894.2-86	Circlip	25	1	
89	.03-053	Bush	30 × 25 × 16	2	
90	.03-054	II- I Gear		1	m1.75z3、 m2.25z19
91	.03-055	II- I Spacer		1	
92	.03-056	I、 II packing			
93	.3-057	I、 II Flange		1	
94	.03-058	A-C Fork		1	
95	.03-059	A-T Lever		2	
96	GB/T2089	Spring	0.8 × 5 × 17	7	
97	GB308-89	Steal Ball	6	6	
98	.03-060	A-T Support Board		1	
99	0.3-061	A-T Shaft		2	
100	GB/T879.2-2000	Pin	4 × 25	2	
101	.03-062	R-T Lever		1	
102	.03-063	7-8 Fork		1	
103	GB/T70.1-2000	Screw	M5 × 20	4	
104	.03-064	5-6 Fork		1	
105	.03-065	3-4 Fork		1	
106	GB/T894.2-86	Circlip	10	2	
107	.03-066	V-Z Shaft		2	
108	.03-067	V-Z Bracket		1	
109	GB/T119.1-2000	Pin	5h6 × 25	1	
110	GB/T879.2-2000	Pin	3 × 6	2	
111	.03-068	V-Z Lever 1		1	
112	.03-069	V-Z Fork		1	

## Gear Box Control (4)

No.	code	name	specification	Qty	Notes
113	GB3452.1-82	O-Ring	10×2.65	3	
114	GB3452.1-82	O-Ring	17×2.65	3	
115	.03-070	Washer		3	
116	GB/G1096-79	Key	4×12	4	
117	.03-071	Washer		3	
118	GB/T70.1-2000	Screw	M5×12	3	
119	.03—072	Handle		3	
120	.03-073	Shaft		1	
121	.03-074	Cam		1	
122	.03-075	Washer		1	
123	GB/T77-2000	Screw	M8×8	1	
124	GB308-89	Steal Ball	6.5	1	
125	.03-076	1-8 Plate		1	
126	.03-077	Sleeve		2	
127	.03-078	Top Plate		2	
128	GB/T70.1-2000	Screw		2	
129	.03-079	1-8 Plate		1	
130	.03-080	7-8 Fork		1	
131	.03-081	Plate		3	
132	.03-082	5-6Fork		1	
133	.03-083	3-4 Fork		1	
134	.03-084	1-2 Fork		1	
135	.03-085	Screw		2	
136	.03-086	1-8 Plate		1	
137	.03-087	1-8 Plate		1	
138	.03-088	V-Z Fork		1	
139	GB/T119.1-2000	Pin	5h6×16	1	
140	0.3-089	V-Z Lever 2	M6×35	1	
141	JB/T7941.1	Sign	A20	1	GB1160.1-89
142	.03-090	1-8 Shaft		1	
143	.03-091	1-8 Lever		1	
144	GB3452.1-92	O-Ring	40×2.65	1	
145	GB3452.1-92	O-Ring	38.7×2.65	1	
146	.03-092	1-8 Cover		1	
147	GB3452.1-92	O-Ring	30×2.65	1	
148	GB/T2089	Spring	1×8×32	1	
149	GB/T70.1-2000	Screw	M5×30	3	
150	.03-093	Bracket		1	

# Apron (1/2)

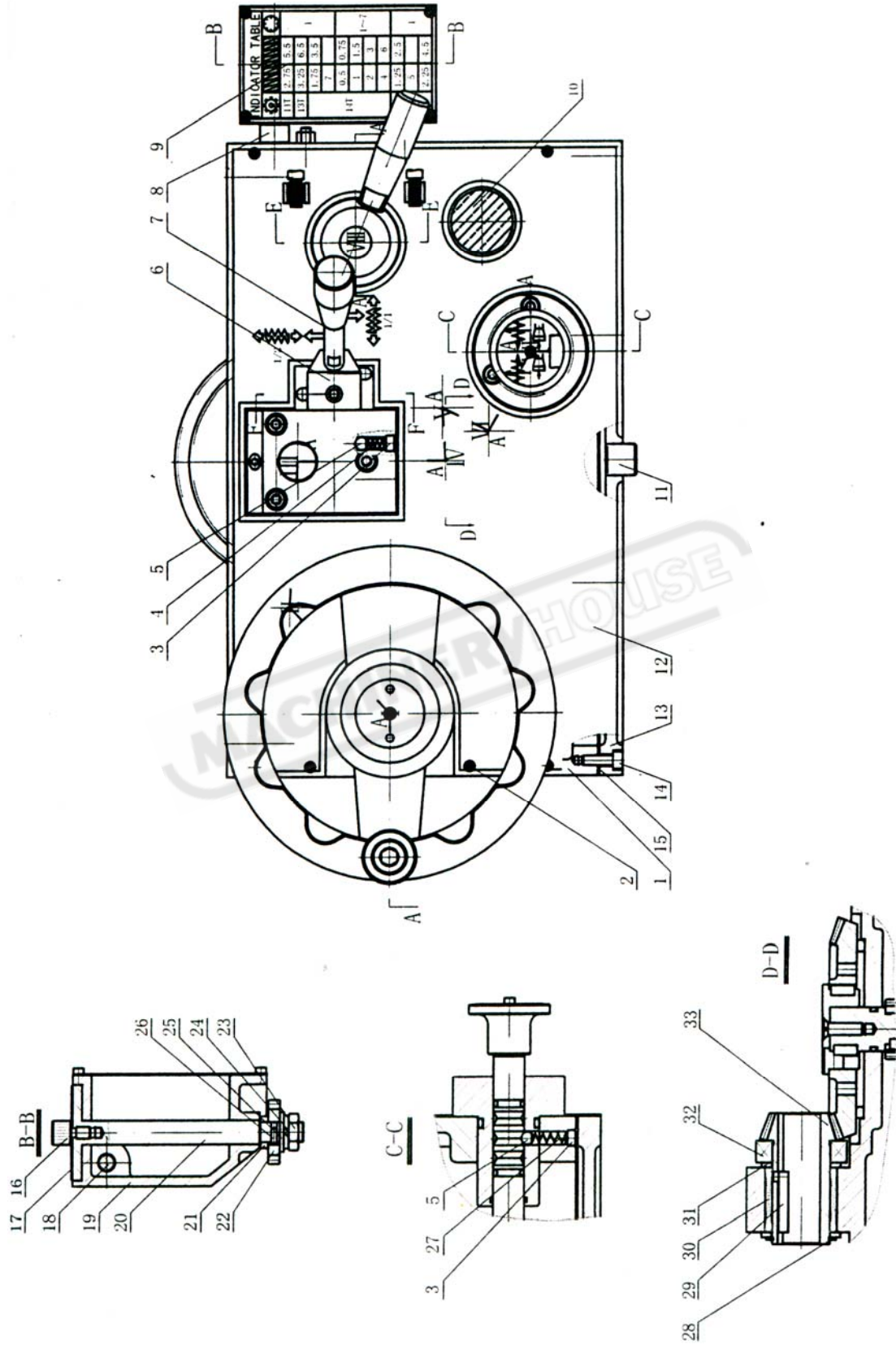

# Apron (1/2)

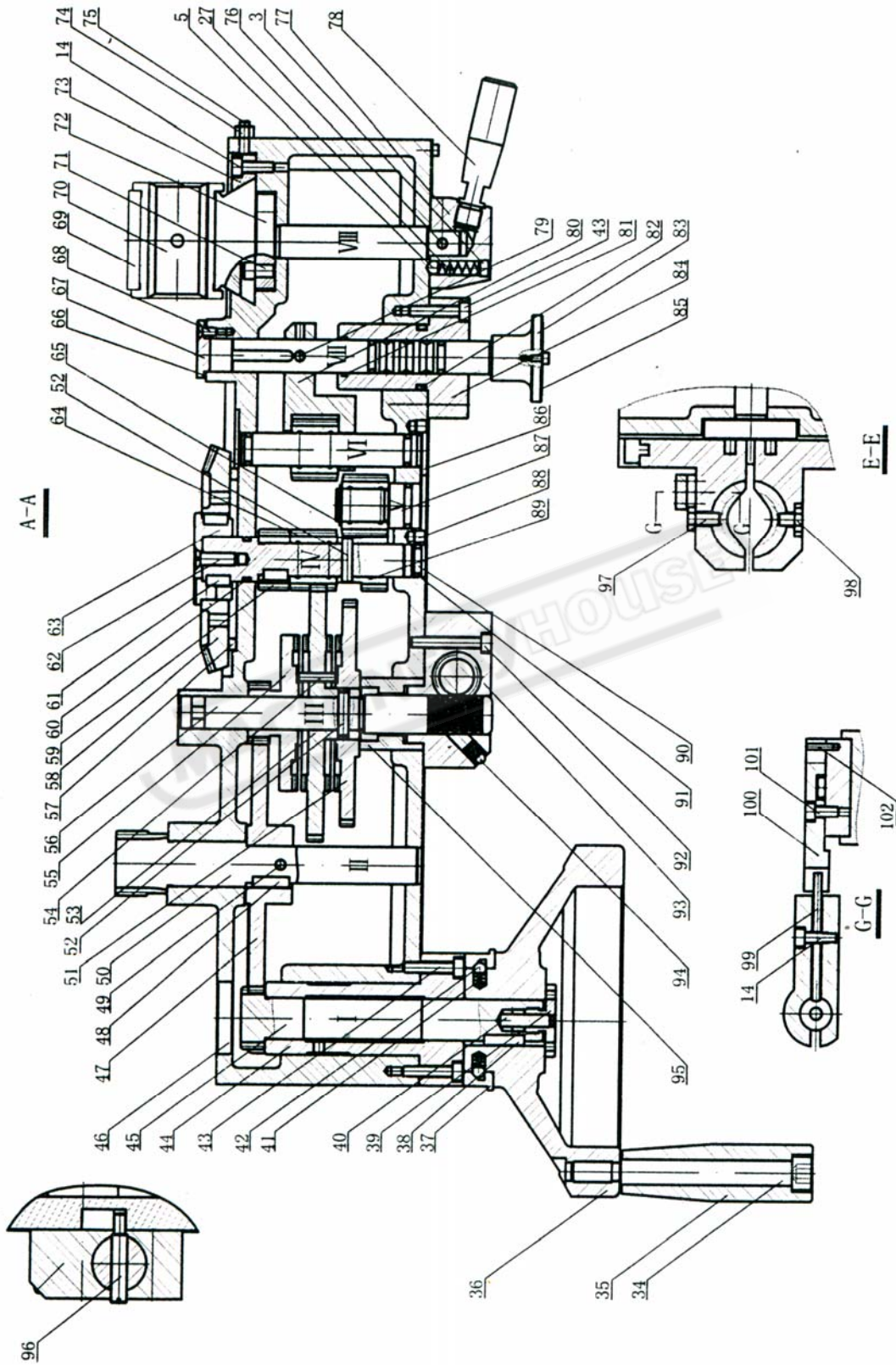

## Apron (1)

No.	code	name	specification	Qty	Notes
1	0.4-001	Apron casting	M3×6	1	
2	GB/T70.1-2000	Screw	M8×6	11	
3	GB/T77-2000	Screw	1×5×15	3	
4	GB/T2089-94	Spring	6.5	1	
5	GB-308-89	Steal Ball		3	
6	.04-040	Shaft		1	
7	.04-016	Handle		1	
8	.04-057	Spacer		1	
9	.04-036	Nameplate		1	
10	GB1160.1-89	Oil Standard	20	1	
11	Q/ZB285.3	Plug	R3/8"	1	
12	.04-003	Nameplate		1	
13	.04-048	Cover		1	
14	GB/T70.1-2000	Screw	M5×16	12	
15	0.4-049	Packing	NY400 δ=1	1	
16	.04-053	Screw		1	
17	.04-055	Sign		1	
18	GBT70.1-2000	Screw	M8×70	1	
19	.04-032	Seat		1	
20	0.4-033	Shaft		1	
21	.04-054	Circlip		1	
22	04-056/1-056/5	Gear		5	One, Comon
23	GB/T6174-2000	Nut	M10	1	
24	GB/T93-97	Circlip	10	1	
25	GB/T97.1-2002	Circlip	10	1	
26	GB/T879.2-2000	Pin	3×8	1	
27	GB/T2089-94	Spring	1×5×25	2	
28	GB/T894.1-86	Circlip	30	1	
29	.04-035	Key		1	
30	GB290-82	Shaft	7943/30	1	
31	0.4-028	Circlip		2	
32	GB/301-95	Shaft	51106	1	30×47×11
33	.04-029	Gear		1	
34	.04-006	Screw		1	
35	0.4-005	Sleeve		1	

## Apron (2)

No.	code	name	specification	Qty	Notes
36	.04-007	Handwheel		1	
37	.04-008	Scale Ring		1	
38	GB/T1096-79	Key	5×5×20	1	
39	.05-117	Screw		2	
40	GB/T70.1-2000	Screw	M6×25	2	
41	GB/2089-94	Spring	0.5×4×12	5	
42	GB308-89	Steal Ball	6	1	
43	GB/T1096-79	Screw	M5×25	1	
44	.04-004	Shaft		1	
45	.04-002	Gear		1	ml.5 z18
46	.04-023	Plug		1	
47	0.4-009	Gear		1	ml.5 z18
48	GB/T1096-79	Key	5×5×18	1	
49	GB/T879.2-2000	Pin	5×35	1	
50	0.4-010	Gear		1	ml.75 z16
51	.04-012	Gear		1	ml.5 z72
52	GB/T879.2-2000	Pin	5×22	2	
53	.04-011	Gear		1	ml.5 z81
54	GB/T119.2-2000	Pin	D4×20	3	
55	0.4-034	Gear		1	ml.5 z18
56	0.4-013	Shaft		1	ml.5 z5
57	0.4-046	Circlip		1	
58	0.4-045	Gear		1	ml.75 z64
59	0.4-047	Gear		1	ml.5 z18
60	GB/T3452.1-82	O-Ring	17×2.65	2	
61	GB/T1096-79	Key	5×5×12	3	
62	GB/T819.1-2000	Screw	M6×20	1	
63	.04-051	Shaft		1	
64	0.4-050	Gear		3	ml.5 z18
65	GB/T894.1-86	Circlip	16	1	
66	0.4-042	Packing	NY400 δ=1	1	
67	.04-043	Cover		1	
68	GB/T819.1-2000	Screw	M4×10	3	
69	0.4-038	Nut Seat		1	
70	0.4-052	Nut		1	



## Apron (3)

No.	code	name	specification	Qty	Notes
71	.04-037	Pin		2	
72	0.4-025	Shaft		1	
73	0.4-030	Plate		1	
74	GB/T41-2000	Nut	M5	2	
75	GB/T77-2000	Screw	M5×16	1	
76	GB/T879.2-2000	Pin	5 ×40	1	
77	.04-026	Head of Handle		1	
78	.04-027	Handle		1	
79	GB/T879.2-2000	Pin	5×30	1	
80	.04-041	Fork		1	
81	GB/T3452.1-82	O-Ring	16×1.8	1	
82	GB/T3452.1-82	O-Ring	28.5×3.55	1	
83	.04-021	Shaft		1	
84	.04-022	Flange		1	
85	.04-020	Nameplate		1	
86	.04-044	Shaft		1	
87	.04-019	Shaft		2	
88	GB/T77-2000	Screw	M6×6	1	
89	.04-017	Gear		1	ml.5 z18
90	.04-024	Cover		1	
91	GB/T3452.1-82	O-Ring	11.2×2.65	5	
92	GB/T70.1-2000	Screw	M5×35	3	
93	.04-014	Lever Bracket		1	
94	GB1155-89	Oil Cup	8	1	
95	.04-015	Sleeve		1	
96	GB/T75-85	Screw	M8×45	1	
97	GB/T5782-2000	Screw	M6×12	1	
98	GB/T5782-2000	Screw	M6×8	1	
99	.04-031	Lever		1	
100	.04-039	Stopper Block		1	
101	GB/T70.1-2000	Screw	M5×12	2	
102	GB/T879.2-2000	Pin	3×14	2	

# Carrriage (1/2)

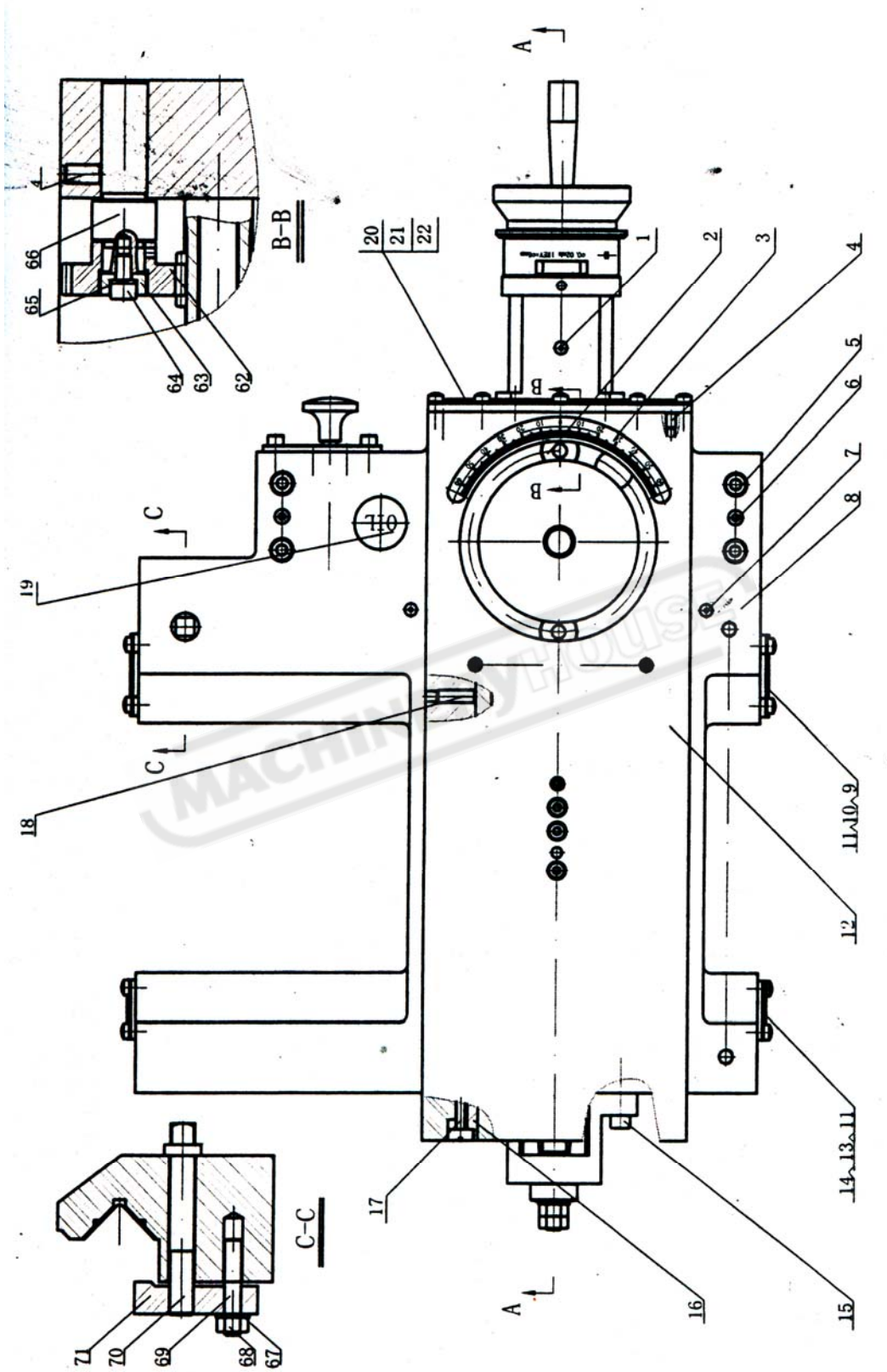

# Carringe (1/2)

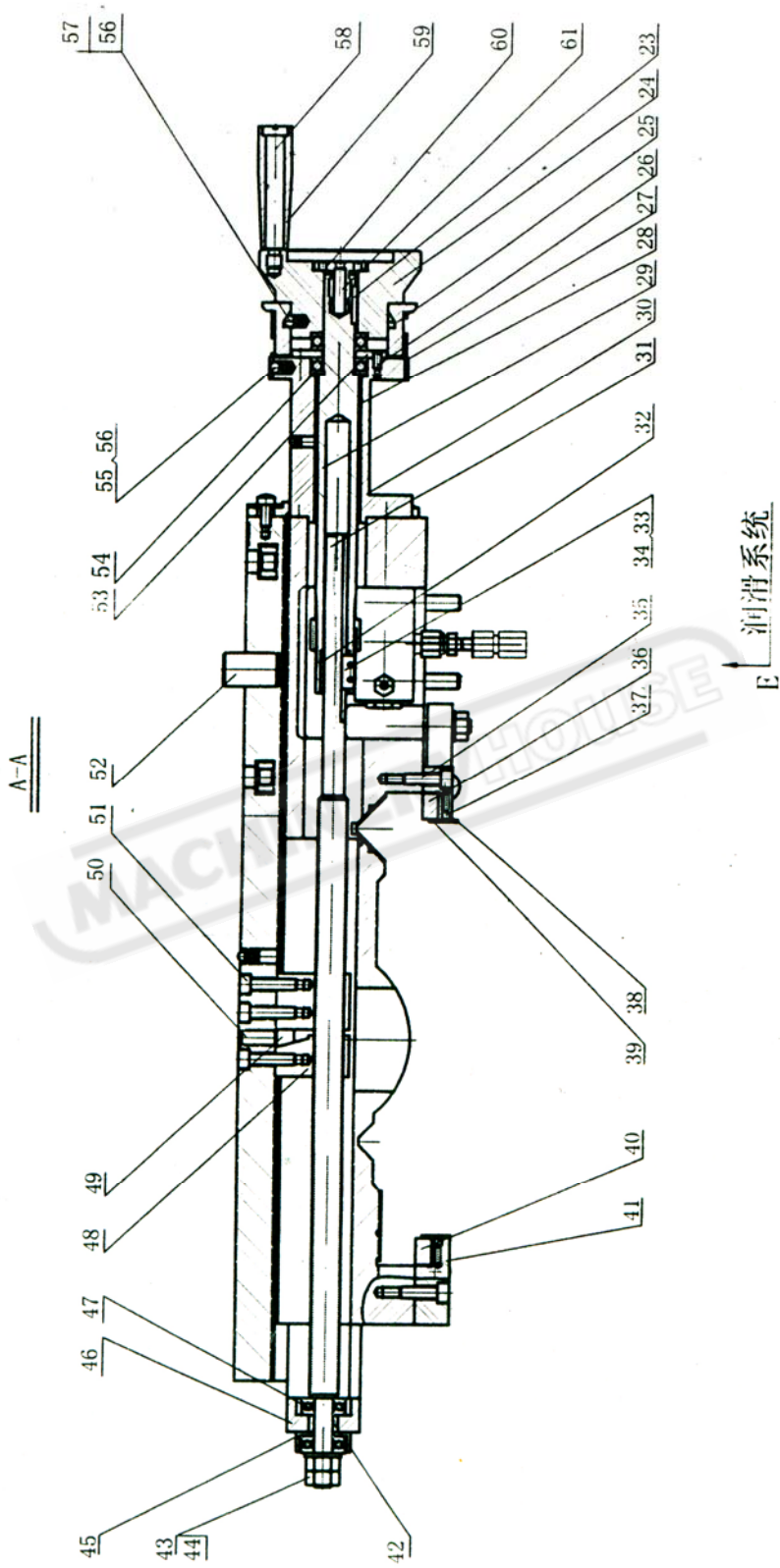

## Carringe (1)

No.	code	name	specification	Qty	Notes
1	GB1155-89	Oil Cup	6	1	
2	.05-130	Nut		2	
3	.05-140	Sign		1	
4	GB/T77-2000	Screw	M6×10	3	
5	GB/T70.1-2000	Screw	M8×70	4	
6	GB/T118-2000	Pin	8×70	2	
7	GB1155-89	Oil Cup	8	5	
8	.05-101	Bed saddle		1	
9	.05-138	Wiper		2	
10	.05-139	Wiper Cover		2	
11	GB/T818-2000	Screw	M5×10	8	
12	.05-102	Cover-cross Sliding		1	
13	.05-136	Wiper		2	
14	.05-137	Wiper Cover		2	
15	GB/T70.1-2000	Screw	M8×25	2	
16	.05-103	Gib		1	
17	.05-127	Screw		6	
18	GB/T77-2000	Screw	M8×25	1	
19	C6241-3100	Gib		1	Borron
20	.05-134	Wiper		1	
21	.05-135	Wiper Cover		1	
22	GB/T818-2000	Screw	M5×12	5	
23	GB/T1096-79	Key	3×20	2	
24	.05-116	Handle		1	
25	.05-115	Dial-Feed		1	
26	GB/T819.1-2000	Screw	M4×10	3	
27	.05-114	Sleeve		1	
28	.05-108	Copper Bush		2	
29	.05-105	Sleeve		1	
30	.05-109	Seat		1	
31	.05-104	Feed Screw		1	
32	.05-107	Copper Bush		1	
33	.05-106	Key		1	
34	GB/T879.2-2000	Pin	2.5×16	2	
35	GB/T70.1-2000	Screw	M6×20	8	
36	.05-125	Iron		1	

## Carringe (2)

No.	code	name	specification	Qty	Notes
37	GB/T819.1-2000	Screw	M4×6	8	
38	.05-124	Wiper Cover		1	
39	.05-126	Iron Block		1	
40	.05-123	Iron		1	
41	.05-122	Wiper Cover		1	
42	.05-111	Copper Bush		1	
43	GB/T41-2000	Nut	M10	2	
44	GB/T97.1-2000	Washer	10	3	
45	.05-112	Seat		1	
46	.05-110	Seat		1	
47	GB/T301-95	Thrust Bearing	51100	2	
48	.05-120	Nut		1	
49	.05-121	Conditioning Block		1	
50	GB/T77-2000	Screw	M8×20	1	
51	GB/T70.1-2000	Screw	M6×25	5	
52	GB/T119.1-2000	Pin	18js6×30	1	
53	.05-113	Washer		1	
54	GB/T301-95	Thrust Bearing	51103	2	
55	GB/T2089-94	Spring	0.5×4×12	1	
56	GB308-89	Ball Cup	6	4	
57	GB/T2089-94	Spring	0.5×4.5×8	3	
58	.05-119	Screw		1	
59	.05-118	Tube		1	
60	.05-117	Screw		1	
61	GB/T77-2000	Screw	M6×25	1	
62	.05-131	Gear		1	
63	.05-132	Washer		1	
64	GB/T70.1-2000	Screw	M5×10	1	
65	GB/93-97	Washer	5	1	
66	.05-133	Shaft		1	
67	GB/T97.1-2002	Washer	8	1	
68	GB/T41-2000	Nut	M8	1	
69	.05-129	Screw		1	
70		Screw	M12×75	1	
71	.05-128	Wiper Cover		1	

# Compound

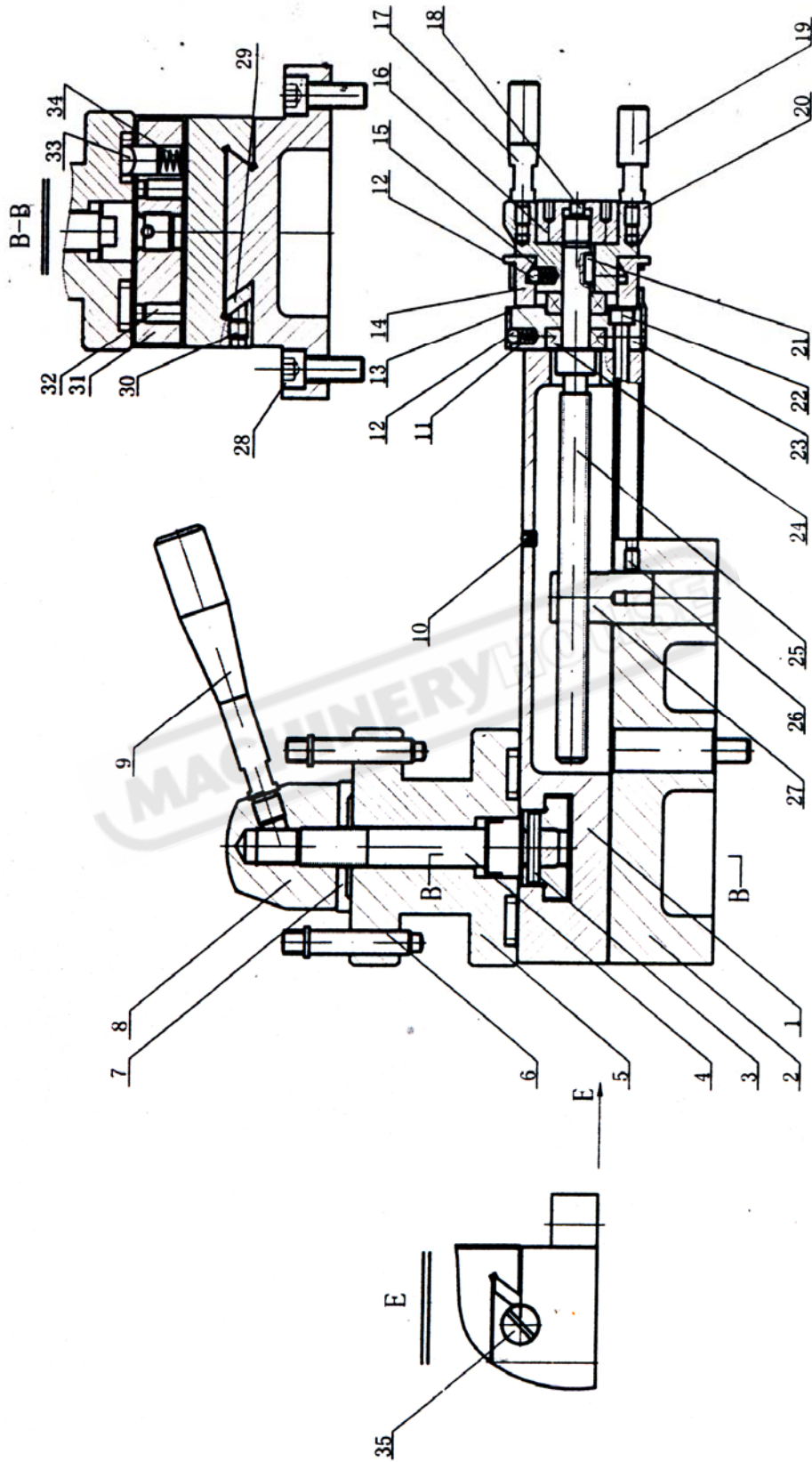



## Compound

No.	code	name	specification	Qty	Notes
1	.05-001	Compound Rest		1	
2	.05-002	Swivel Table		1	
3	GB/T879.2-2000	Cylindrical Pin	5×30	1	
4	.05-010	Screw		1	
5	.05-013	Tool Post		1	
6	GB93-83	Screw	M10×50	12	
7	.05-012	Washer		1	
8	0.5-015	Clamping Handle		1	
9	0.5-016	Clamp Headle		1	
10	GB11500-89	Oil Cup	6	1	
11	GB/T2089-94	Spring	0.5×4×12	1	
12	GB308-89	Steel Ball	6	4	
13	.05-007	Sleeve		1	
14	.05-006	Dial-compound Rest		1	
15	GB/T2089-94	Spring	0.5×4.5×8	3	
16	.05-008-008	Nut		1	
17	.05-018	Handle		1	
18	GB/T77-2000	Screw	M6×6	1	
19	.05-019	Handle		1	
20	.05-017	Handle		1	
21	GB1096-79	Key	4×4×12	1	
22	GB/T70.1-2000	Screw	M6×25	2	
23	.05-005	Seat		1	
24	GB/T301-95	Thrust Bearing	51101	2	12×26×9
25	.05-004	Feed Screw		1	
26	GB/T70.1-2000	Screw	M6×10	1	
27	.05-003	Nut		1	
28	GB/T70.1-2000	Screw	M10×25	2	
29	.05-009	Gib		1	
30	GB/T77-2000	Screw	M8×8	1	
31	.05-014	Positioning Block		1	
32	GB/T77-2000	Screw	M8×18	2	
33	.05-011	Pin		1	
34	GB-T2089-94	Spring	1×8×11	1	
35	.05-020	Screw		2	

# Lubrication

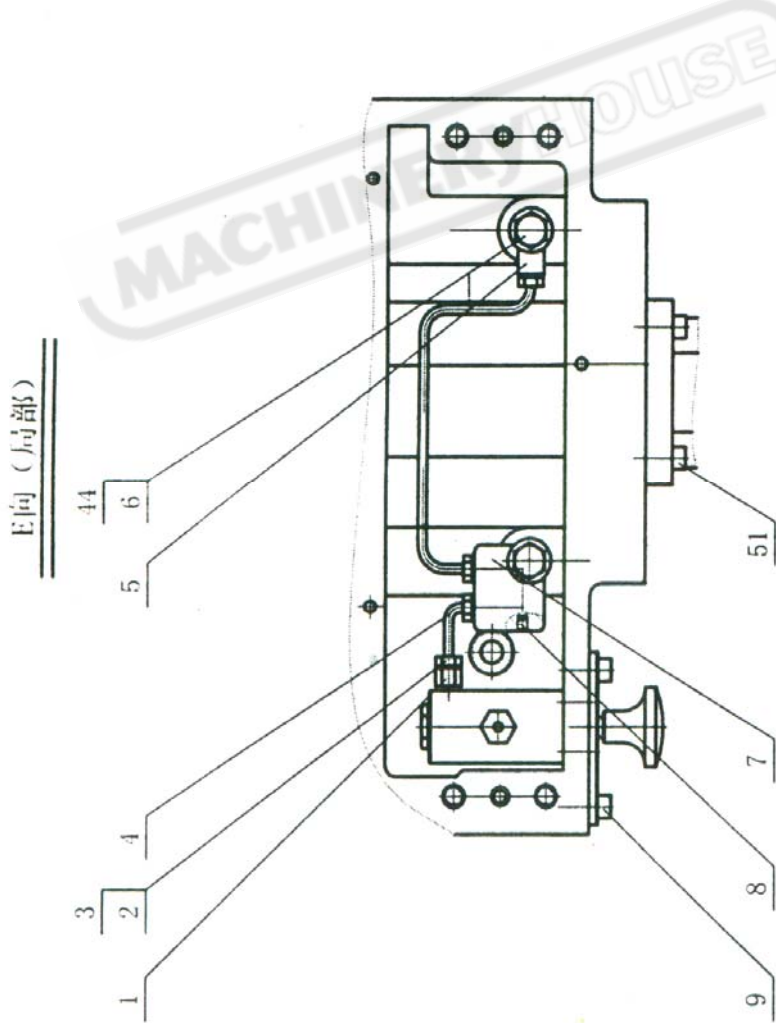
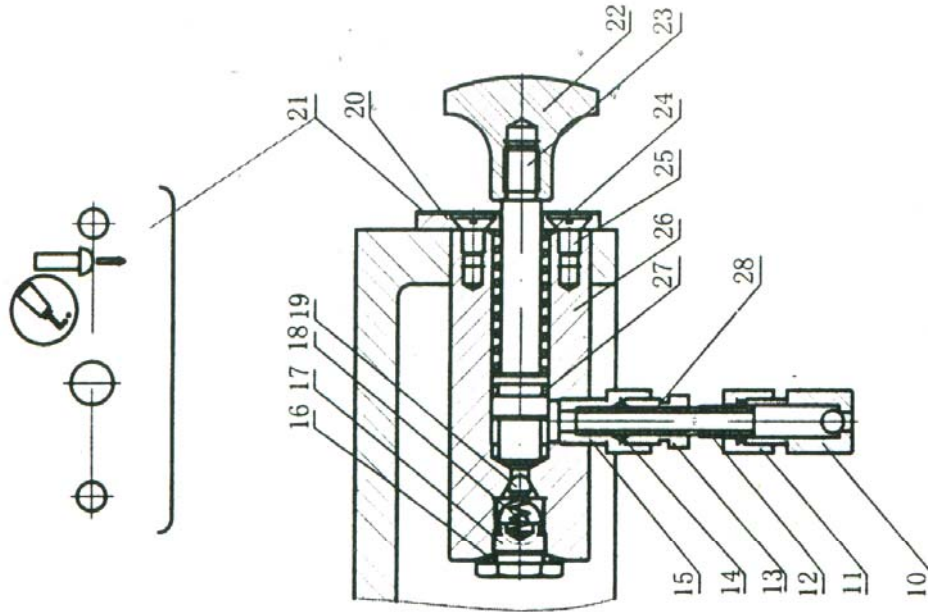

## Lubrication

No.	code	name	specification	Qty	Notes
1		Tie-In.		1	
2		Tie-In.		4	
3		Double Cone Ring	4	4	
4		Lubrication tube	直径 4×0.75	(Qty)	
5	.05-149	Oiler		1	
6	.05-147	Bolt		2	
7	.05-148	Distributoy		1	
8	GB/T77-2000	Screw	M4×6	1	
9	GB/T77.1-2000	Screw	M6×12	1	
10		One-way Valve		1	
11		Nut		1	
12		Single taper Sheath	直径 6	1	
13		Tie-In.	直径 6	1	
14		Double taper Sheath	直径 6	1	
15		Tie-In		1	
16	GB3452.1-82	O-Ring	11.2×1.8	1	
17	.05-146	Hexagon Plug		1	
18	GB/T2089-89	Spring	0.5×4.5×15	1	
19	GB308-89	Ball	5	1	
20	.05-142	Plate		1	
21	.05-141	Sign		1	
22	.05-144	Handle		1	
23	.05-143	Piston		1	
24	GB/T2089-94	Spring	1.4×11×40	1	
25	GB/T819.1-2000	Screw	M5×8	8	
26	.05-145	Pump		1	
27	GB3452.1-82	O-Ring	9×1.8	1	
28		Lubrication tube	直径×1	(Qty)	

# Tail Stock Assembl (1/2)

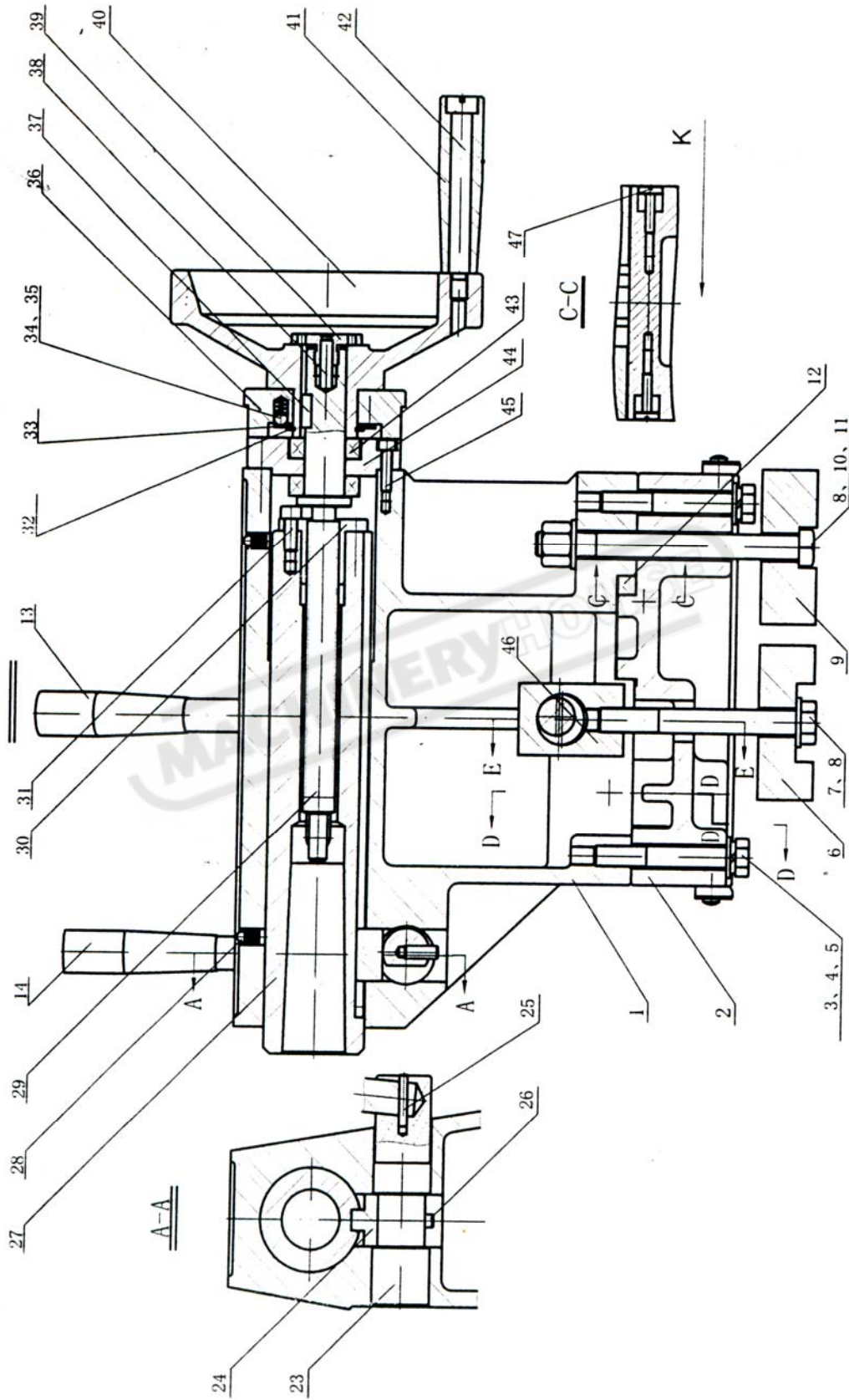

# Tail Stock Assembl (2/2)

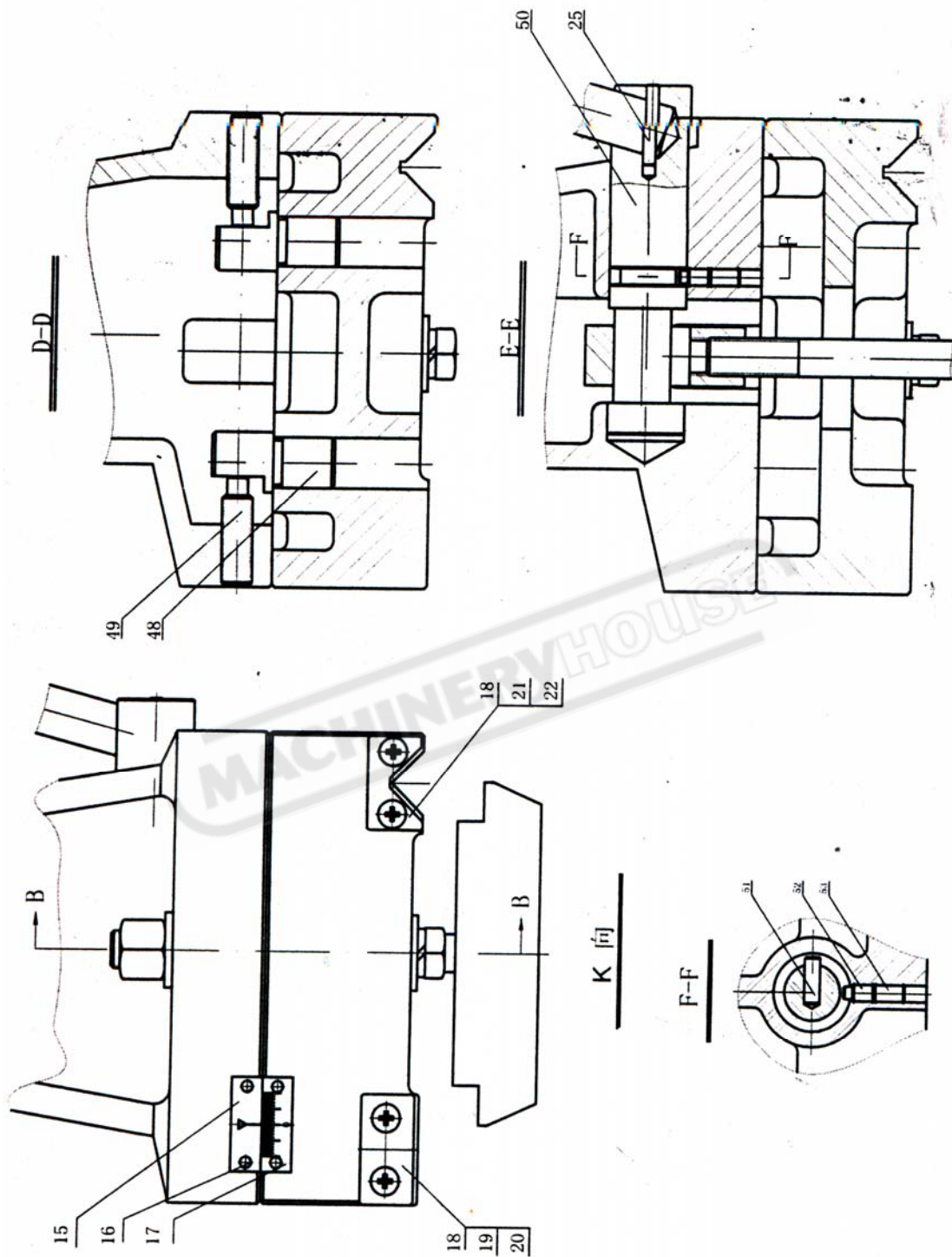

## Tail Stock Assembl (1)

No.	code	name	specification	Qty	Notes
1	.06-001	Tail Stock		1	
2	.06-002	Tail Stock Bose		1	
3	GB//T5780-2000	Screw	M10×70	2	
4	GB/T95-2000	Retaining Ring	10	2	
5	GB/T93-87	Spring Washer	10	2	
6	.06-003	Bedway Wiper Plate		1	
7	GB/T5780-2000	Screw	M12×100	1	
8	GB/T95-2000	Retaining Ring	2	2	
9	.06-004	Bedway Wiper Plate		1	
10	GB/T5780-2000	Screw	M12×130	1	
11	GB/T56-88	Hexagon Thick Nut	M12	1	
12	.06-005	Gib		1	
13	.06-006	Handle		1	
14	.06-007	Handle		1	
15	CQ6230-6014	Sign		1	Borrow
16	GB827-99	Quill	2×4	4	
17	CQ6230-6016	Sign		1	Borrow
18	GB/T818-2000	Screw	M4×12	8	
19	.03-008	Bedway Wiper		2	
20	.06-009	Bedway Wiperplate		2	
21	.06-010	Bedway Wiper		2	
22	.06-011	Bedway Wiperplate		2	
23	.06-012	Clamping Shaft		1	
24	.06-013	Key		1	
25	GB/T119.2-2000	Cylindrical Pin	4×25	2	
26	GB/T77-2000	Screw	M6×16	1	
27	.06-014	Quill		1	
28	GB1155-89	Oil Cup	8	2	



## Tail Stock Assembl (2)

No.	code	name	specification	Qty	Notes
29	.06-015	Feed Screw		1	
30	.06-016	Feed Nut		1	
31	GB/T70.1-2000	Screw	M6×16	3	
32	GB/T894.1-86	Retaining Ring	32	1	
33	.06-017	Retaining Ring		1	
34	GB308-89	Steel Ball	6.5	3	
35	GB/T2089-94	Spring	06×5×16	3	
36	.06-018	Dial		1	
37	GB/T1096-79	Key	5×5×16	1	
38	GB/T78-2000	Screw	M6×16	1	
39	.06-019	Screw		1	
40	.06-020	Hand wheel		1	
41	.06-021	Handle		1	
42	.06-022	Bolt		1	
43	GB/T301-95	Shaft	51104	2	20×35×10
44	.06-023	Bracket		1	
45	GB/T70.1-2000	Screw	M5×20	3	
46	.06-024	Adjusting Block		1	
47	.06-025	Screw		2	
48	.06-026	Shaft		1	
49	GB/T79-2000	Screw	M10×35	2	
50	.06-027	Clamping Block		1	
51	GB/T879.2-2000	Cylindrical Pin	5×15	1	
52	GB/T79-2000	Screw	M6×10	1	
53	GB/T77-2000	Screw	M6×10	1	

# Steady Rest

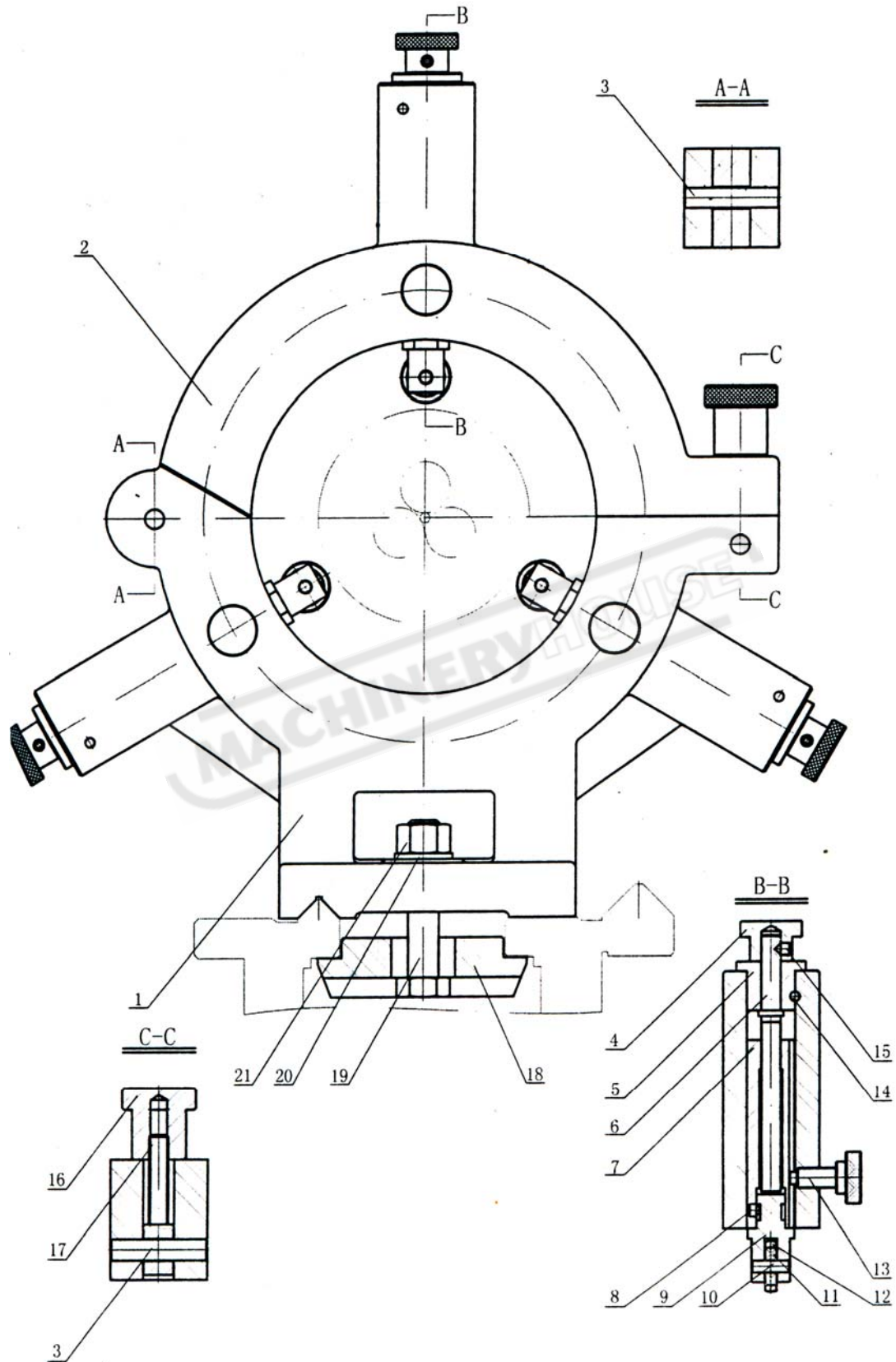

## Steady Rest

No.	code	name	specification	Qty	Notes
1	.08-201	Upside of Steady Rest		1	
2	.08-202	Downside of Steady Res		2	
3	GB/T119.1-2000	Pin	10m6×50	3	
4	.08-203	Sleeve		3	
5	.08-204	Bush		3	
6	.08-205	Screw Shaft		3	
7	.08-206	Sleeve		3	
8	GB/T77-2000	Screw	M6×6	3	
9	.08-207	Bracket		3	
10	GB/T119.1-2000	Pin	6m6×20	3	
11	GB278-94	Shaft	626	3	6×19×6
12	.08-211	Sleeve		3	
13	0.8-208	Screw		3	
14	GB879.2-2000	Pin	5×12	3	
15	GB/T78-2000	Screw	M6×8	3	
16	.08-209	Nut		1	
17	.08-210	Screw		31	
18	.08-212	Plate		1	
19	GB/T5780-2000	Bolt	M16×80	1	
20	GB/T97.1-2002	Circlip	16	1	
21	GB.T6170-2000	Nut	M16	1	

# Follow Rest

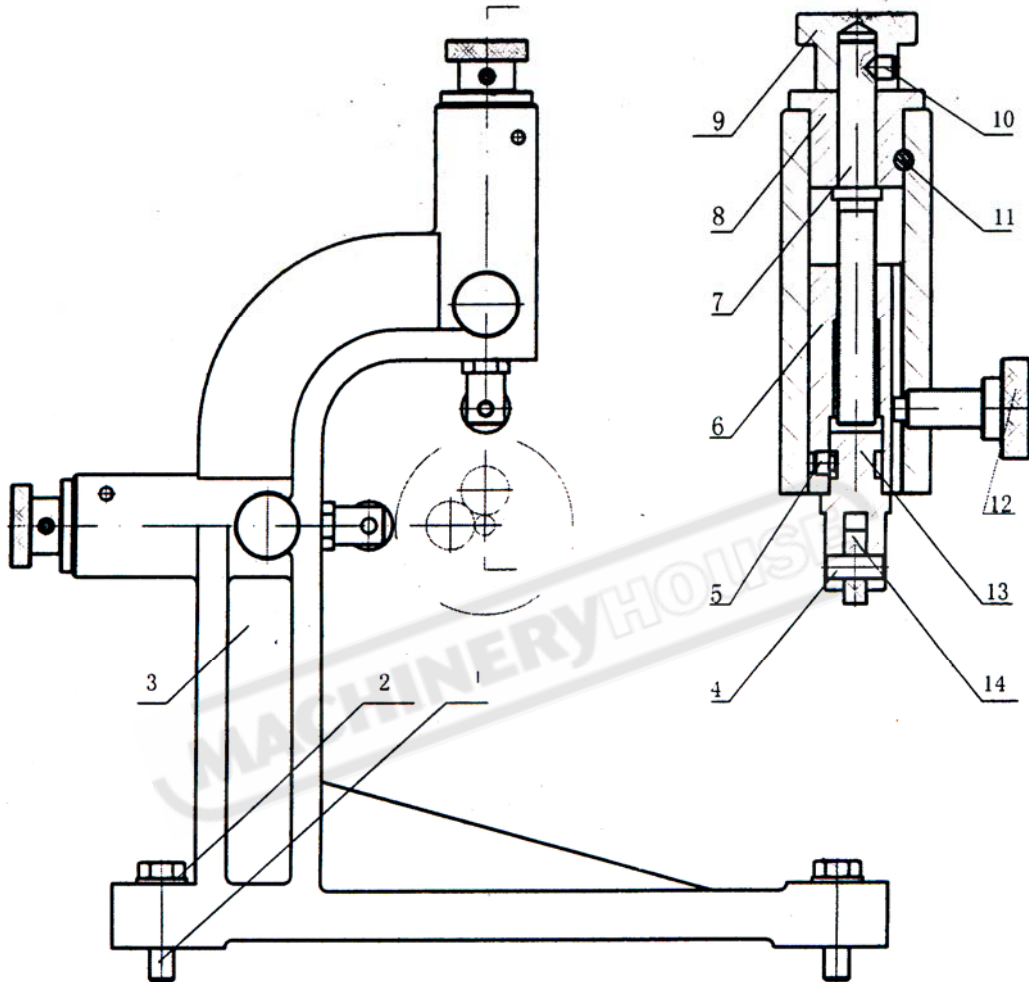

## Follow Rest

No.	code	name	specification	Qty	Notes
1	GB/T5782-2000	Bolt	M10×10	2	
2	GB/T97.1-2002	Washer	10	2	
3	.08-301	Follow Rest		1	
4	GB/T119.1-2000	Pin	6m6×6	2	
5	GB/T77-2000	Screw	M6×6	2	
6	.08-302	Sleeve		2	
7	.08-303	Screw Shaft		2	
8	.08-204	Bush		2	Borrow
9	.08-203	Rotate Handle		2	Borrow
10	GB/T78-2000	Screw	M6×8	2	
11	GB879.2-2000	Pin	5×26	2	
12	.08-208	Limited Screw		2	
13	.08-304	Support Shaft		2	
14	GB/278-94	Bearing	626	2	6×19×6

# Chuck Guard Cover

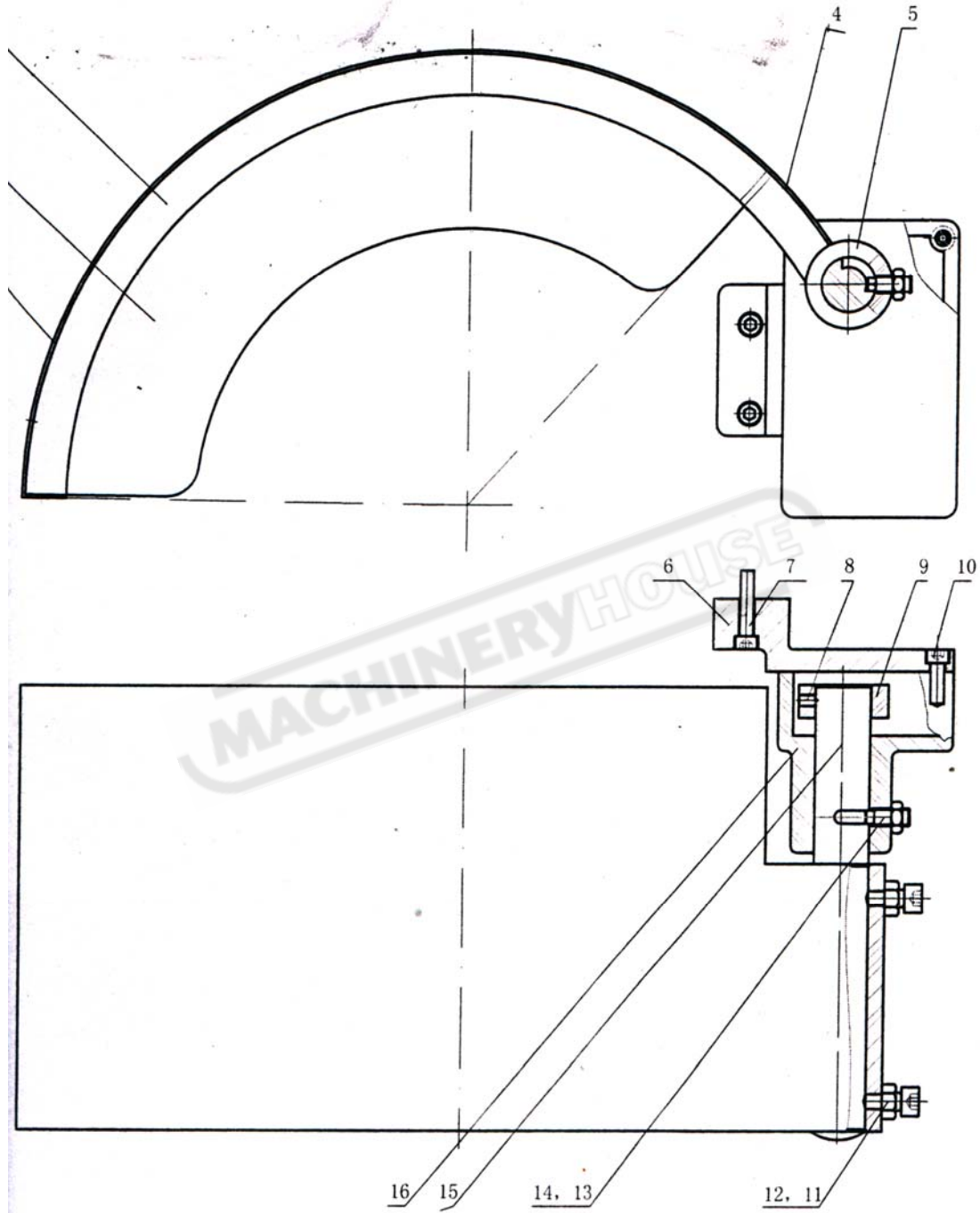



## Chuck Guard Cover

No.	code	name	specification	Qty	Notes
1	.08-903/1	Plate		1	
2	.08-903/2	Plate		1	
3	.08-903/3	Plate		1	
4	.08-903/4	Plate		1	
5	.08-903/5	Quill		1	
6	C6241-8904	Cover Bracket		1	Borrow
7	GB/T70.1-2000	Screw	M6×30	2	
8	GB/T78-2000	Screw	M6×10	1	
9	C624-8905	Set		1	Borrow
10	GB/T70.1-2000	Screw	M6×20	4	
11	GB/T70.1-2000	Screw	M8×20	2	
12	GB/T6175-2000	Nut	M8	2	
13	GB/T79-2000	Screw	M6×20	1	
14	GB/T6175-2000	Nut		1	
15	08-902	Shaft		1	
16	C6241-8901	Guard Electrical Box		1	Borrow